

# CATHEDRAL OF BENGHAZI BENGHAZI, LIBIA



Architectural, electric and mechanical systems project

Architect in charge  
and team coordinator:

Arch. Carlo Formichi

بحاز تنمية و تطوير  
المراكز الادارية



DRAWING

**ES2.08**

**WORKING DESIGN  
ELECTRICAL PATTERNS  
CATHEDRAL, BUILDINGS 1 & 3**

SCALE

/

PATTERNS OF ELECTRICAL PANELBOARDS

DATE: May 2009

UPDATING:

PROJECT NAME S09\_04

PLANT INPUT	
FAULT CURRENT ALLEGED ON PANELBOARD	5 [kA]
RATED VOLTAGE	400 (V)
RATED FREQUENCY	50 (Hz)
SYSTEM OF NEUTRAL	TT
PANELBOARD NAME	
PB3Z	
DP 31	SEGREGATION 3
NORMATIVE REFERENCE	
SWITCH	CEI EN 60947-2
MODULAR SWITCH	CEI EN 60947-2
	CEI EN 60898
PANELBOARD	CEI EN 60439-1
DIMENSION COPPER BARS	
$I_n = 160$ [A]	$I_{cc} = 10,00$ [kA]

PANEL NAME  
Panelboard Building 3 – Floor Z



















































CLIENT :

OBJECT

*Cathedral of Benghazi – Building 3*

TABLE: 01

# LEGEND SYMBOLS

SYMBOL	DESCRIPTION	SYMBOL	DESCRIPTION	SYMBOL	DESCRIPTION	SYMBOL	DESCRIPTION
	BATTERY ACCUMULATORI		PUSH SWITCH NO N.A.		CONTACTOR		METER
	RECTIFIER RADDRIZZATORE		PUSH SWITCH NC N.C.		PHASE WIRE		AMPEROMETRIC AND AMMETRIC SWITCH
	INVERTER C.C. - A.C.		SIGNAL LAMP		NEUTRAL WIRE		RELAY
	CONTROL ISOLATION "ISOLTESTER"		ELECTRIC SIREN		EXTRACTABLE SWITCH		DELAY TO DISEXCITATION RELAY
	AUXILIARY CONTACT NO		FUSE		SAFETY ISOLATING TRASFORMERS		DELAY TO EXCITATION RELAY
	AUXILIARY CONTACT NC		DIODE		TRANSFORMER		TWILIGHT SWITCH
	AUXILIARY CONTACT OF THERMAL RELAY NO		AUTOMATIC CIRCUIT BREAKER		RIDUTTORE DI CORRENTE (TA)		THREE PHASE MOTOR A.C.
	AUXILIARY CONTACT OF THERMAL RELAY NC		ISOLATOR		EARTH CONNECTION		MONO PHASE MOTOR A.C.
	AUXILIARY CONTACT TIMED TO THE EXCITATION NO		MAGNETIC AND THERMAL SWITCH		KEY LOCK		THREE PHASE CAPACITOR
	AUXILIARY CONTACT TIMED TO THE EXCITATION NC		MAGNETIC, THERMAL AND RESIDUAL CURRENT SWITCH		LOCK		
	AUXILIARY CONTACT TIMED TO THE DISEXCITATION NO		RESIDUAL CURRENT SWITCH		TIME SWITCH		
	AUXILIARY CONTACT TIMED TO THE DISEXCITATION NC		SWITCH		TERMINAL		
	PROXIMITY SWITCH NO		FUSE-DISCONNECTOR		VOLTMETER		
	PROXIMITY SWITCH NC		EARTHING SWITCH		AMPEROMETER		

PROJECT NAME S09\_04

PLANT INPUT	
FAULT CURRENT ALLEGED ON PANELBOARD	5 [kA]
RATED VOLTAGE	400 (V)
RATED FREQUENCY	50 (Hz)
SYSTEM OF NEUTRAL	TT
PANELBOARD NAME	
PB3Z	
DP 31	SEGREGATION 3
NORMATIVE REFERENCE	
SWITCH	CEI EN 60947-2
MODULAR SWITCH	CEI EN 60947-2
	CEI EN 60898
PANELBOARD	CEI EN 60439-1
DIMENSION COPPER BARS	
$I_n = 160$ [A]	$I_{cc} = 10,00$ [kA]

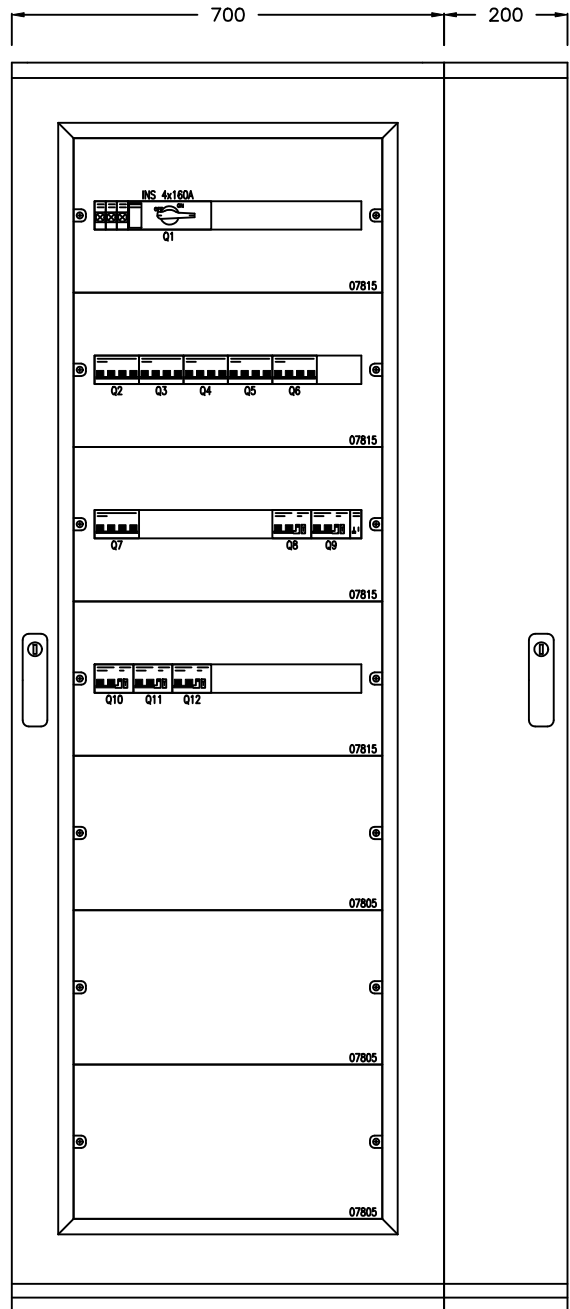

DIMENSION PANEL

HEIGHT [mm] : 2.000 BREADTH [mm] : 1.800 DEPTH [mm] : 400





PROJECT NAME S09\_04

PLANT INPUT	
FAULT CURRENT ALLEGED ON PANELBOARD	1,3 [KA]
RATED VOLTAGE	400 (V)
RATED FREQUENCY	50 (Hz)
SYSTEM OF NEUTRAL	TT
PANELBOARD NAME	
PB3A	
DP 31	SEGREGATION 3
NORMATIVE REFERENCE	
SWITCH	CEI EN 60947-2
MODULAR SWITCH	CEI EN 60947-2
	CEI EN 60898
PANELBOARD	CEI EN 60439-1
DIMENSION COPPER BARS	
In=	40 [A]    Icc= 6,00 [KA]

PANEL NAME  
Panelboard Building 3 – Floor A



















































CLIENT :

OBJECT

*Cathedral of Benghazi – Building 3*

TABLE: 02

# LEGEND SYMBOLS

SYMBOL	DESCRIPTION	SYMBOL	DESCRIPTION	SYMBOL	DESCRIPTION	SYMBOL	DESCRIPTION
	BATTERY ACCUMULATORI		PUSH SWITCH NO N.A.		CONTACTOR		METER
	RECTIFIER RADDRIZZATORE		PUSH SWITCH NC N.C.		PHASE WIRE		AMPEROMETRIC AND AMMETRIC SWITCH
	INVERTER C.C. - A.C.		SIGNAL LAMP		NEUTRAL WIRE		RELAY
	CONTROL ISOLATION "ISOLTESTER"		ELECTRIC SIREN		EXTRACTABLE SWITCH		DELAY TO DISEXCITATION RELAY
	AUXILIARY CONTACT NO		FUSE		SAFETY ISOLATING TRASFORMERS		DELAY TO EXCITATION RELAY
	AUXILIARY CONTACT NC		DIODE		TRANSFORMER		TWILIGHT SWITCH
	AUXILIARY CONTACT OF THERMAL RELAY NO		AUTOMATIC CIRCUIT BREAKER		RIDUTTORE DI CORRENTE (TA)		THREE PHASE MOTOR A.C.
	AUXILIARY CONTACT OF THERMAL RELAY NC		ISOLATOR		EARTH CONNECTION		MONO PHASE MOTOR A.C.
	AUXILIARY CONTACT TIMED TO THE EXCITATION NO		MAGNETIC AND THERMAL SWITCH		KEY LOCK		THREE PHASE CAPACITOR
	AUXILIARY CONTACT TIMED TO THE EXCITATION NC		MAGNETIC, THERMAL AND RESIDUAL CURRENT SWITCH		LOCK		
	AUXILIARY CONTACT TIMED TO THE DISEXCITATION NO		RESIDUAL CURRENT SWITCH		TIME SWITCH		
	AUXILIARY CONTACT TIMED TO THE DISEXCITATION NC		SWITCH		TERMINAL		
	PROXIMITY SWITCH NO		FUSE-DISCONNECTOR		VOLTMETER		
	PROXIMITY SWITCH NC		EARTHING SWITCH		AMPEROMETER		

PROJECT NAME S09\_04

PLANT INPUT	
FAULT CURRENT ALLEGED ON PANELBOARD	1,3 [kA]
RATED VOLTAGE	400 (V)
RATED FREQUENCY	50 (Hz)
SYSTEM OF NEUTRAL	TT
PANELBOARD NAME	
PB3A	
DP 31	SEGREGATION 3
NORMATIVE REFERENCE	
SWITCH	CEI EN 60947-2
MODULAR SWITCH	CEI EN 60947-2
	CEI EN 60898
PANELBOARD	CEI EN 60439-1
DIMENSION COPPER BARS	
$I_n = 40$ [A]	$I_{cc} = 6,00$ [kA]

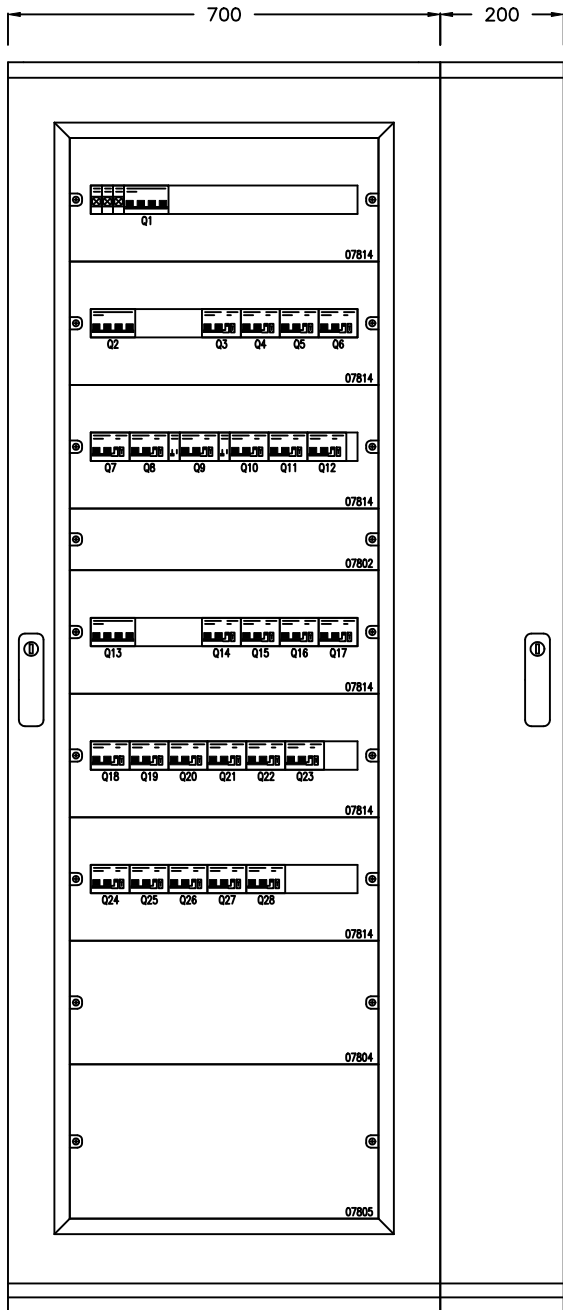

DIMENSION PANEL

HEIGHT [mm] : 2.000 BREADTH [mm] : 900 DEPTH [mm] : 400









PROJECT NAME S09\_04

PLANT INPUT	
FAULT CURRENT ALLEGED ON PANELBOARD	1,3 [KA]
RATED VOLTAGE	400 (V)
RATED FREQUENCY	50 (Hz)
SYSTEM OF NEUTRAL	TT
PANELBOARD NAME	
PB3B	
DP 31	SEGREGATION 3
NORMATIVE REFERENCE	
SWITCH	CEI EN 60947-2
MODULAR SWITCH	CEI EN 60947-2
	CEI EN 60898
PANELBOARD	CEI EN 60439-1
DIMENSION COPPER BARS	
In=	50 [A]    Icc= 6,00 [KA]

PANEL NAME  
Panelboard Building 3 – Floor B



















































CLIENT :

OBJECT

*Cathedral of Benghazi – Building 3*

TABLE: 03

# LEGEND SYMBOLS

SYMBOL	DESCRIPTION	SYMBOL	DESCRIPTION	SYMBOL	DESCRIPTION	SYMBOL	DESCRIPTION
	BATTERY ACCUMULATORI		PUSH SWITCH NO N.A.		CONTACTOR		METER
	RECTIFIER RADDRIZZATORE		PUSH SWITCH NC N.C.		PHASE WIRE		AMPEROMETRIC AND AMMETRIC SWITCH
	INVERTER C.C. - A.C.		SIGNAL LAMP		NEUTRAL WIRE		RELAY
	CONTROL ISOLATION "ISOLTESTER"		ELECTRIC SIREN		EXTRACTABLE SWITCH		DELAY TO DISEXCITATION RELAY
	AUXILIARY CONTACT NO		FUSE		SAFETY ISOLATING TRASFORMERS		DELAY TO EXCITATION RELAY
	AUXILIARY CONTACT NC		DIODE		TRANSFORMER		TWILIGHT SWITCH
	AUXILIARY CONTACT OF THERMAL RELAY NO		AUTOMATIC CIRCUIT BREAKER		RIDUTTORE DI CORRENTE (TA)		THREE PHASE MOTOR A.C.
	AUXILIARY CONTACT OF THERMAL RELAY NC		ISOLATOR		EARTH CONNECTION		MONO PHASE MOTOR A.C.
	AUXILIARY CONTACT TIMED TO THE EXCITATION NO		MAGNETIC AND THERMAL SWITCH		KEY LOCK		THREE PHASE CAPACITOR
	AUXILIARY CONTACT TIMED TO THE EXCITATION NC		MAGNETIC, THERMAL AND RESIDUAL CURRENT SWITCH		LOCK		
	AUXILIARY CONTACT TIMED TO THE DISEXCITATION NO		RESIDUAL CURRENT SWITCH		TIME SWITCH		
	AUXILIARY CONTACT TIMED TO THE DISEXCITATION NC		SWITCH		TERMINAL		
	PROXIMITY SWITCH NO		FUSE-DISCONNECTOR		VOLTMETER		
	PROXIMITY SWITCH NC		EARTHING SWITCH		AMPEROMETER		

PROJECT NAME S09\_04

PLANT INPUT	
FAULT CURRENT ALLEGED ON PANELBOARD	1,3 [KA]
RATED VOLTAGE	400 (V)
RATED FREQUENCY	50 (Hz)
SYSTEM OF NEUTRAL	TT
PANELBOARD NAME	
PB3B	
DP 31	SEGREGATION 3
NORMATIVE REFERENCE	
SWITCH	CEI EN 60947-2
MODULAR SWITCH	CEI EN 60947-2
	CEI EN 60898
PANELBOARD	CEI EN 60439-1
DIMENSION COPPER BARS	
$I_n = 50$ [A]	$I_{cc} = 6,00$ [KA]

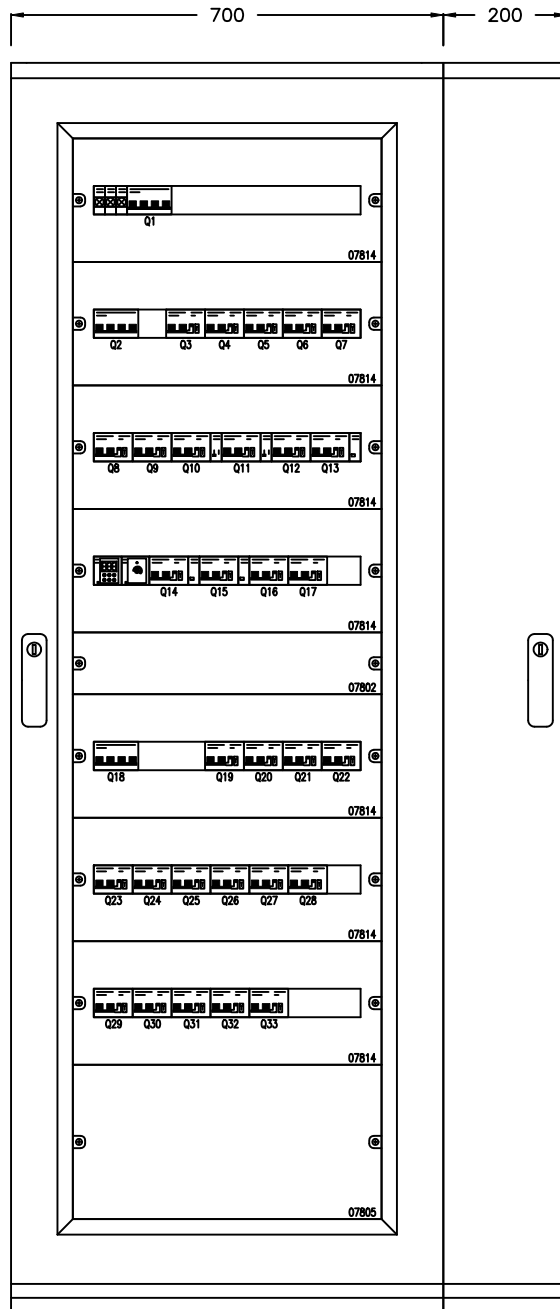

DIMENSION PANEL

HEIGHT [mm] : 2.000 BREADTH [mm] : 900 DEPTH [mm] : 400



REFERENCE NUMBER OF DEVICE	1	2	3	4	5	6	7	8	9	10	11	12
PROJECT NAME	SO9_04											

PLANT INPUT	
FAULT CURRENT ALLEGED ON PANELBOARD	1,3 [kA]
RATED VOLTAGE	400 (V)
RATED FREQUENCY	50 (Hz)
SYSTEM OF NEUTRAL	TT
PANELBOARD NAME	
PB3B	
DP 31	SEGREGATION 3
NORMATIVE REFERENCE	
SWITCH	CEI EN 60947-2
MODULAR SWITCH	CEI EN 60947-2
	CEI EN 60898
PANELBOARD	CEI EN 60439-1
DIMENSION COPPER BARS	
In=	50 [A]
Icc=	6,00 [kA]

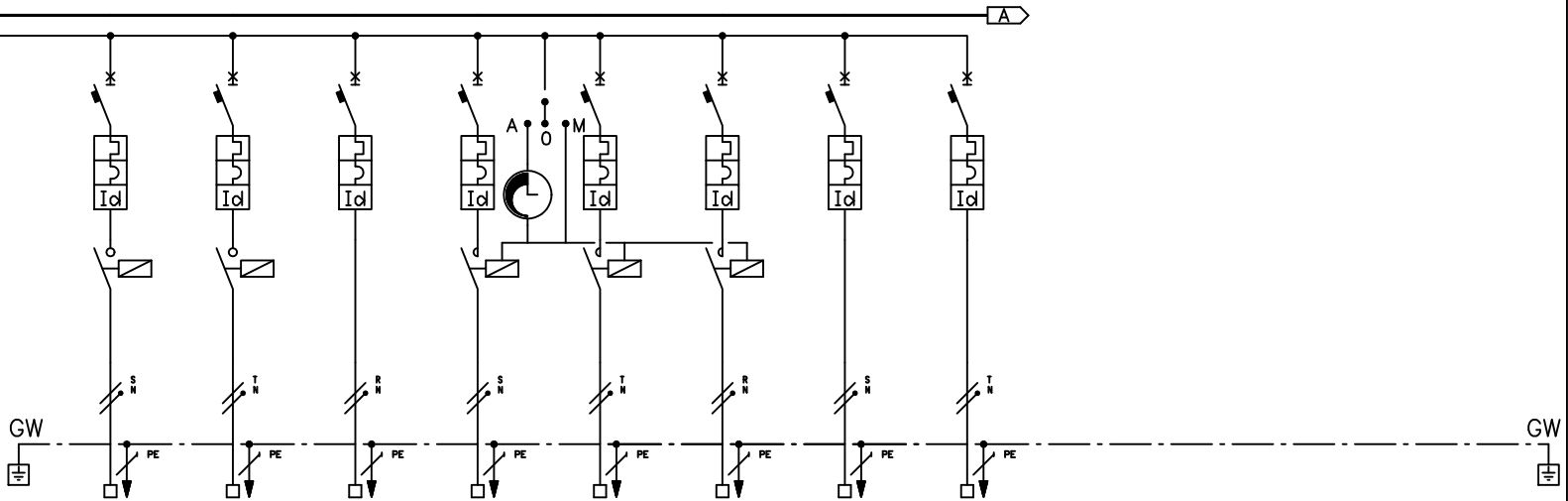

USER	SWITCH NAME		Q10	Q11	Q12	Q13	Q14	Q15	Q16	Q17											
	CIRCUIT NAME		L8	L9	L10	L11	L12	L13													
	DESCRIPTION OF THE CIRCUIT		Passage 3.B11 - 3.B12	Stairs 3BVS1	Emergency Lighting	External passage	External Lighting 1 Ground floor	External Lighting 2 Ground floor	Spare	Spare											
	INSTALLED ELECTRIC POWER	[kVA]	0,49	0,20	0,08	0,17	0,72	0,72													
	INSTALLED ELECTRIC POWER	[kW]	0,44	0,18	0,07	0,15	0,65	0,65													
	COEF. OF CONTEMPORANEITY		1,00	1,00	1,00	1,00	1,00	1,00													
	COEF. OF UTILISATION		1,00	1,00	1,00	1,00	1,00	1,00													
	USED ELECTRIC POWER	[kW]	0,44	0,18	0,07	0,15	0,65	0,65													
	THREE OR MONO PHASE SYSTEM		M	M	M	M	M	M													
	VOLTAGE	[V]	220	220	220	220	220	220													
	Cos φ		0,90	0,90	0,90	0,90	0,90	0,90													
	ELECTRICAL CURRENT USED	[A]	2,2	0,9	0,4	0,8	3,3	3,3													
	Icc ALLEGED	[kA]	1,300	1,300	1,300	1,300	1,300	1,300	1,300	1,300	1,300	1,300	1,300	1,300	1,300	1,300	1,300	1,300	1,300	1,300	1,300
	TYPE		Miniature	Miniature	Miniature	Miniature	Miniature	Miniature	Miniature	Miniature	Miniature	Miniature	Miniature	Miniature	Miniature	Miniature	Miniature	Miniature	Miniature	Miniature	Miniature
	SIZE		2x10	2x6	2x6	2x6	2x10	2x10	2x10	2x10	2x10	2x10	2x10	2x10	2x10	2x10	2x10	2x10	2x10	2x10	2x10
	CHARACTERISTICS		C	C	C	C	C	C	C	C	C	C	C	C	C	C	C	C	C	C	C
	MAGNETIC RELEASE I <sub>rm</sub>	[A]	100	60	60	60	100	100	100	100	100	100	100	100	100	100	100	100	100	100	100
	THERMAL RELEASE I <sub>rh</sub>	[A]	10,0	6,0	6,0	6,0	10,0	10,0	10,0	10,0	10,0	10,0	10,0	10,0	10,0	10,0	10,0	10,0	10,0	10,0	10,0
	BREAKING CAPACITY	[kA]	6,0	6,0	6,0	6,0	10,0	10,0	6,0	6,0	6,0	6,0	6,0	6,0	6,0	6,0	6,0	6,0	6,0	6,0	6,0
	I <sub>βt</sub>	[A <sup>2t</sup> ]	4,860E+03	3,660E+03	3,660E+03	3,660E+03	4,860E+03	4,860E+03	4,860E+03	4,860E+03	4,860E+03	4,860E+03	4,860E+03	4,860E+03	4,860E+03	4,860E+03	4,860E+03	4,860E+03	4,860E+03	4,860E+03	4,860E+03
	RATED SENSITIVITY	[A]	0,03	0,03	0,03	0,03	0,03	0,03	0,03	0,03	0,03	0,03	0,03	0,03	0,03	0,03	0,03	0,03	0,03	0,03	0,03
	DELAY	[ms]																			
	TYPE		Latching	Latching		Contactor	Contactor	Contactor													
	N. POLES x In	[A]	2x16	2x16		2x16	2x16	2x16													
	THERMAL RELAY																				
	THERMAL RELEASE I <sub>rh</sub>	[A]																			
	FUSE																				
	N. POLI x In	[A]																			
	CONNECTION																				
	SETTING																				
	TYPE		B	B	B	B	B	B													
	NO. OF CORES X AREA	[mm <sup>2</sup> ]	4	4	4	4	6	6													
	GROUND WIRE (GW)	[mm <sup>2</sup> ]	3G2,5	3G2,5	3G2,5	3G2,5	3G4	3G4													
	NO. OF WIRE X POLE		1	1	1	1	1	1													
	LENGTH	[m]	40	20	40	50	150	150													
	ΔV%	[%]	0,75	0,15	0,14	0,34	2,62	2,62													
	CURRENT CARRYING CAPACITY	[A]	31	31	31	31	42	42													
	k <sup>2</sup> s <sup>2</sup>	[A <sup>2t</sup> ]	1,560E+05	1,560E+05	1,560E+05	1,560E+05	3,994E+05	3,994E+05													
	MINIMUM Icc	[A]	261	491	261	210	114	114													
	MAX Icc	[A]	261	491	261	210	114	114													
	MAXIMUM LENGTH CHECKED	[m]	106	176	176	176	170	170													





PROJECT NAME S09\_04

PLANT INPUT	
FAULT CURRENT ALLEGED ON PANELBOARD	2,00 [kA]
RATED VOLTAGE	400 (V)
RATED FREQUENCY	50 (Hz)
SYSTEM OF NEUTRAL	TT
PANELBOARD NAME	PC
DP 31 SEGREGATION	3
NORMATIVE REFERENCE	
SWITCH	CEI EN 60947-2
MODULAR SWITCH	CEI EN 60947-2
	CEI EN 60898
PANELBOARD	CEI EN 60439-1
DIMENSION COPPER BARS	
$I_n =$	80 [A] $I_{cc} =$ 10,00 [kA]

PANEL NAME  
Panelboard Cathedral



















































CLIENT :

OBJECT :

*Cathedral of Benghazi*

TABLE: 04

# LEGEND SYMBOLS

SYMBOL	DESCRIPTION	SYMBOL	DESCRIPTION	SYMBOL	DESCRIPTION	SYMBOL	DESCRIPTION
	BATTERY ACCUMULATORI		PUSH SWITCH NO N.A.		CONTACTOR		METER
	RECTIFIER RADDRIZZATORE		PUSH SWITCH NC N.C.		PHASE WIRE		AMPEROMETRIC AND AMMETRIC SWITCH
	INVERTER C.C. - A.C.		SIGNAL LAMP		NEUTRAL WIRE		RELAY
	CONTROL ISOLATION "ISOLTESTER"		ELECTRIC SIREN		EXTRACTABLE SWITCH		DELAY TO DISEXCITATION RELAY
	AUXILIARY CONTACT NO		FUSE		SAFETY ISOLATING TRASFORMERS		DELAY TO EXCITATION RELAY
	AUXILIARY CONTACT NC		DIODE		TRANSFORMER		TWILIGHT SWITCH
	AUXILIARY CONTACT OF THERMAL RELAY NO		AUTOMATIC CIRCUIT BREAKER		RIDUTTORE DI CORRENTE (TA)		THREE PHASE MOTOR A.C.
	AUXILIARY CONTACT OF THERMAL RELAY NC		ISOLATOR		EARTH CONNECTION		MONO PHASE MOTOR A.C.
	AUXILIARY CONTACT TIMED TO THE EXCITATION NO		MAGNETIC AND THERMAL SWITCH		KEY LOCK		THREE PHASE CAPACITOR
	AUXILIARY CONTACT TIMED TO THE EXCITATION NC		MAGNETIC, THERMAL AND RESIDUAL CURRENT SWITCH		LOCK		
	AUXILIARY CONTACT TIMED TO THE DISEXCITATION NO		RESIDUAL CURRENT SWITCH		TIME SWITCH		
	AUXILIARY CONTACT TIMED TO THE DISEXCITATION NC		SWITCH		TERMINAL		
	PROXIMITY SWITCH NO		FUSE-DISCONNECTOR		VOLTMETER		
	PROXIMITY SWITCH NC		EARTHING SWITCH		AMPEROMETER		

PROJECT NAME S09\_04

PLANT INPUT	
FAULT CURRENT ALLEGED ON PANELBOARD	2,00 [kA]
RATED VOLTAGE	400 (V)
RATED FREQUENCY	50 (Hz)
SYSTEM OF NEUTRAL	TT
PANELBOARD NAME	
PC	
DP 31	SEGREGATION 3
NORMATIVE REFERENCE	
SWITCH	CEI EN 60947-2
MODULAR SWITCH	CEI EN 60947-2
	CEI EN 60898
PANELBOARD	CEI EN 60439-1
DIMENSION COPPER BARS	
$I_n =$	80 [A]
$I_{cc} =$	10,00 [kA]

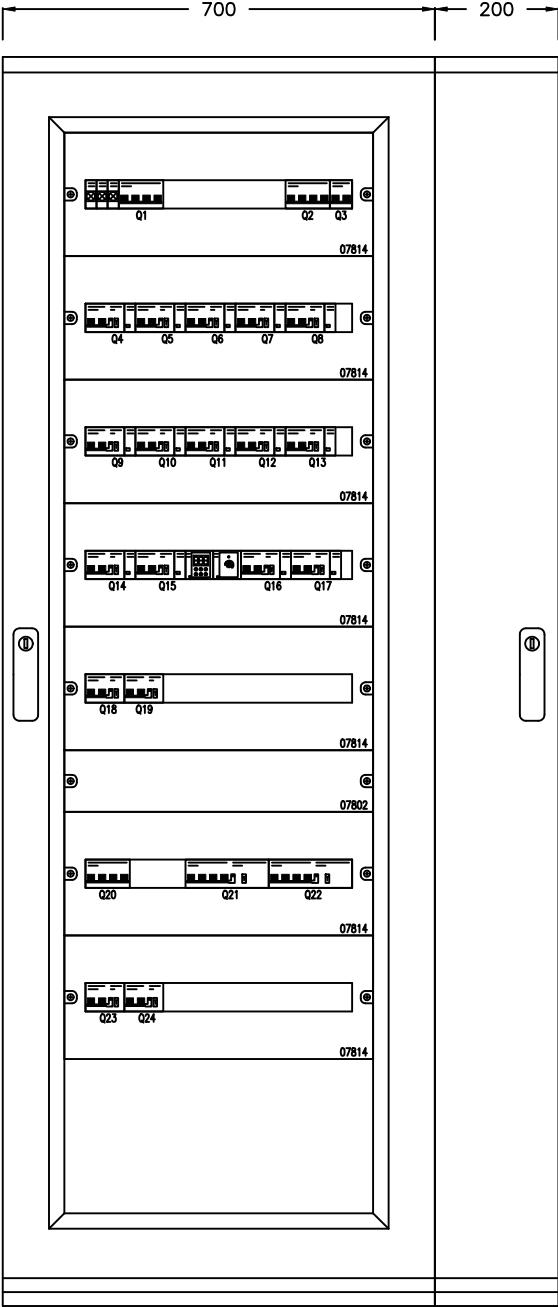

DIMENSION PANEL			
HEIGHT [mm] :	2.000	BREADTH [mm] :	900
		DEPTH [mm] :	400



REFERENCE NUMBER OF DEVICE	1	2	3	4	5	6	7	8	9	10	11	12
PROJECT NAME	SO9_04											

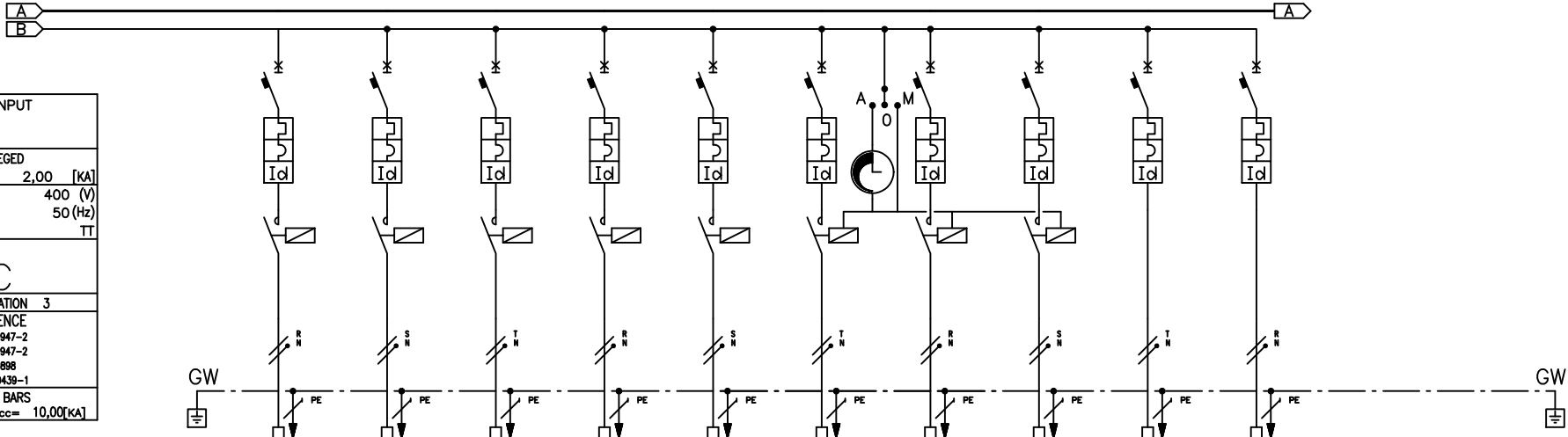

PLANT INPUT	
FAULT CURRENT ALLEGED ON PANELBOARD	2,00 [kA]
RATED VOLTAGE	400 (V)
RATED FREQUENCY	50 (Hz)
SYSTEM OF NEUTRAL	TT
PANELBOARD NAME	
PC	
DP 31	SEGREGATION 3
NORMATIVE REFERENCE	
SWITCH	CEI EN 60947-2
MODULAR SWITCH	CEI EN 60947-2
	CEI EN 60898
PANELBOARD	CEI EN 60439-1
DIMENSION COPPER BARS	
In=	80 [A]
Icc=	10,00[kA]

USER	SWITCH NAME	
	CIRCUIT NAME	
	DESCRIPTION OF THE CIRCUIT	
	INSTALLED ELECTRIC POWER	[kVA]
	INSTALLED ELECTRIC POWER	[kW]
	COEF. OF CONTEMPORANEITY	
	COEF. OF UTILISATION	
	USED ELECTRIC POWER	[kW]
	THREE OR MONO PHASE SYSTEM	
	VOLTAGE	[V]
Cos φ		
ELECTRICAL CURRENT USED	[A]	
DATA PANELBOARD	Icc ALLEGED	[kA]
	TYPE	
SWITCH OR DISCONNECTOR	SIZE	
	CHARACTERISTICS	
	MAGNETIC RELEASE I <sub>rm</sub>	[A]
	THERMAL RELEASE I <sub>rh</sub>	[A]
	BREAKING CAPACITY	[kA]
RESIDUAL CURRENT DEVICE	I <sub>Δn</sub>	[A]
	DELAY	[ms]
COMMAND DEVICE	TYPE	
	N. POLES x In	[A]
THERMAL RELAY	THERMAL RELEASE I <sub>rh</sub>	[A]
FUSE	N. POLI x In	[A]
CONNECTION	SIZE	[mm <sup>2</sup> ]
	SETTING	
WIRE	TYPE	
	NO. OF CORES X AREA	[mm <sup>2</sup> ]
	GROUND WIRE (GW)	[mm <sup>2</sup> ]
	NO. OF WIRE X POLE	
CHECK	LENGTH	[m]
	ΔV%	[%]
	CURRENT CARRYING CAPACITY	[A]
	k <sup>2</sup> s <sup>2</sup>	[A <sup>2</sup> t]
	MINIMUM Icc	[A]
WIRE	MAX Icc	[A]
	MAXIMUM LENGTH CHECKED	[m]

Q10	Q11	Q12	Q13	Q14	Q15	Q16	Q17	Q18	Q19		
L7	L8	L9	L10	L11	L12	L13	L14				
Ledge Circuit 5	Ledge Circuit 6	Floodligh Circuit 1	Floodligh Circuit 2	Chapels	Principal entry	Floodligh roof Circuit 1	Floodligh roof Circuit 2	Spare	Spare		
2,22	2,22	0,83	1,33	0,56	0,44	1,67	1,67				
2,00	2,00	0,75	1,20	0,50	0,40	1,50	1,50				
1,00	1,00	1,00	1,00	1,00	1,00	1,00	1,00				
1,00	1,00	1,00	1,00	1,00	1,00	1,00	1,00				
2,00	2,00	0,75	1,20	0,50	0,40	1,50	1,50				
M	M	M	M	M	M	M	M				
220	220	220	220	220	220	220	220				
0,90	0,90	0,90	0,90	0,90	0,90	0,90	0,90				
10,1	10,1	3,8	6,1	2,5	2,0	7,6	7,6				
2,000	2,000	2,000	2,000	2,000	2,000	2,000	2,000	2,000	2,000	2,000	2,000
Miniature	Miniature	Miniature	Miniature	Miniature	Miniature	Miniature	Miniature	Miniature	Miniature	Miniature	Miniature
2x20	2x20	2x16	2x16	2x10	2x16	2x16	2x16	2x16	2x16	2x16	2x16
C	C	C	C	C	C	C	C	C	C	C	C
200	200	160	160	100	160	160	160	160	160	160	160
20,0	20,0	16,0	16,0	10,0	16,0	16,0	16,0	16,0	16,0	16,0	16,0
10,0	10,0	10,0	10,0	10,0	10,0	10,0	10,0	10,0	10,0	10,0	10,0
5,000E+03	5,000E+03	5,000E+03	5,000E+03	5,000E+03	5,000E+03	5,000E+03	5,000E+03	5,000E+03	5,000E+03	5,000E+03	5,000E+03
0,03	0,03	0,03	0,03	0,03	0,03	0,03	0,03	0,03	0,03	0,03	0,03
Contactor	Contactor	Contactor	Contactor	Contactor	Contactor	Contactor	Contactor				
2x25	2x25	2x25	2x25	2x25	2x25	2x25	2x25				
16	16	10	10	10	10	10	10				
B	B	B	B	B	B	B	B				
FG7	FG7	FG7	FG7	FG7	FG7	FG7	FG7				
3G10	3G10	3G6	3G6	3G6	3G6	3G6	3G6				
1	1	1	1	1	1	1	1				
140	140	120	130	200	100	100	120				
2,90	2,90	1,61	2,80	1,77	0,71	2,69	3,23				
74	74	54	54	54	54	54	54				
2,496E+06	2,496E+06	8,987E+05	8,987E+05	8,987E+05	8,987E+05	8,987E+05	8,987E+05				
314	314	213	197	129	255	255	213				
314	314	213	197	129	255	255	213				
222	222	160	160	255	160	160	160				



PROJECT NAME S09\_04

PLANT INPUT	
FAULT CURRENT ALLEGED ON PANELBOARD	5 [kA]
RATED VOLTAGE	400 (V)
RATED FREQUENCY	50 (Hz)
SYSTEM OF NEUTRAL	TT
PANELBOARD NAME	
PB1Z	
DP 31	SEGREGATION 3
NORMATIVE REFERENCE	
SWITCH	CEI EN 60947-2
MODULAR SWITCH	CEI EN 60947-2
	CEI EN 60898
PANELBOARD	CEI EN 60439-1
DIMENSION COPPER BARS	
$I_n = 250$ [A]	$I_{cc} = 10,00$ [kA]

PANEL NAME  
Panelboard Building 1 – Floor Z



















































CLIENT :

OBJECT

*Cathedral of Benghazi – Building 1*

TABLE: 05

# LEGEND SYMBOLS

SYMBOL	DESCRIPTION	SYMBOL	DESCRIPTION	SYMBOL	DESCRIPTION	SYMBOL	DESCRIPTION
	BATTERY ACCUMULATORI		PUSH SWITCH NO N.A.		CONTACTOR		METER
	RECTIFIER RADDRIZZATORE		PUSH SWITCH NC N.C.		PHASE WIRE		AMPEROMETRIC AND AMMETRIC SWITCH
	INVERTER C.C. - A.C.		SIGNAL LAMP		NEUTRAL WIRE		RELAY
	CONTROL ISOLATION "ISOLTESTER"		ELECTRIC SIREN		EXTRACTABLE SWITCH		DELAY TO DISEXCITATION RELAY
	AUXILIARY CONTACT NO		FUSE		SAFETY ISOLATING TRASFORMERS		DELAY TO EXCITATION RELAY
	AUXILIARY CONTACT NC		DIODE		TRANSFORMER		TWILIGHT SWITCH
	AUXILIARY CONTACT OF THERMAL RELAY NO		AUTOMATIC CIRCUIT BREAKER		RIDUTTORE DI CORRENTE (TA)		THREE PHASE MOTOR A.C.
	AUXILIARY CONTACT OF THERMAL RELAY NC		ISOLATOR		EARTH CONNECTION		MONO PHASE MOTOR A.C.
	AUXILIARY CONTACT TIMED TO THE EXCITATION NO		MAGNETIC AND THERMAL SWITCH		KEY LOCK		THREE PHASE CAPACITOR
	AUXILIARY CONTACT TIMED TO THE EXCITATION NC		MAGNETIC, THERMAL AND RESIDUAL CURRENT SWITCH		LOCK		
	AUXILIARY CONTACT TIMED TO THE DISEXCITATION NO		RESIDUAL CURRENT SWITCH		TIME SWITCH		
	AUXILIARY CONTACT TIMED TO THE DISEXCITATION NC		SWITCH		TERMINAL		
	PROXIMITY SWITCH NO		FUSE-DISCONNECTOR		VOLTMETER		
	PROXIMITY SWITCH NC		EARTHING SWITCH		AMPEROMETER		

PROJECT NAME S09\_04

PLANT INPUT	
FAULT CURRENT ALLEGED ON PANELBOARD	5 [kA]
RATED VOLTAGE	400 (V)
RATED FREQUENCY	50 (Hz)
SYSTEM OF NEUTRAL	TT
PANELBOARD NAME	
PB1Z	
DP 31	SEGREGATION 3
NORMATIVE REFERENCE	
SWITCH	CEI EN 60947-2
MODULAR SWITCH	CEI EN 60947-2 CEI EN 60898
PANELBOARD	CEI EN 60439-1
DIMENSION COPPER BARS	
$I_n$	= 250 [A]
$I_{cc}$	= 10,00 [kA]

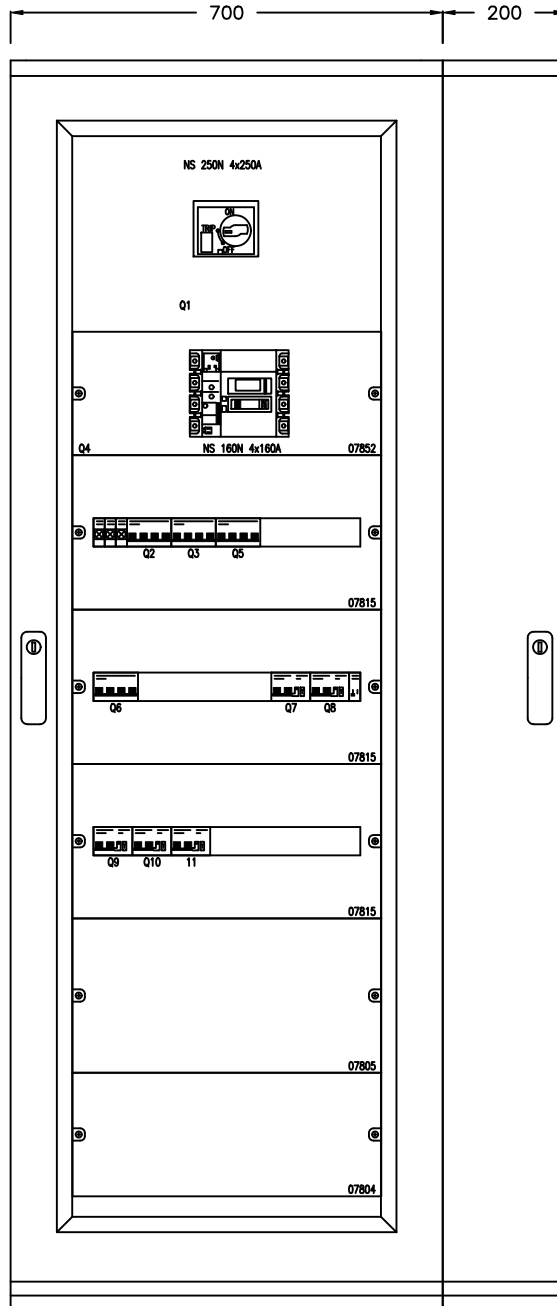

DIMENSION PANEL

HEIGHT [mm] : 2.000 BREADTH [mm] : 1.800 DEPTH [mm] : 400

REFERENCE NUMBER OF DEVICE	1	2	3	4	5	6	7	8	9	10	11	12
PROJECT NAME	S09_04											

PLANT INPUT	
FAULT CURRENT ALLEGED ON PANELBOARD	5 [kA]
RATED VOLTAGE	400 (V)
RATED FREQUENCY	50 (Hz)
SYSTEM OF NEUTRAL	TT
PANELBOARD NAME	PB1Z
DP 31 SEGREGATION	3
NORMATIVE REFERENCE	
SWITCH I	CEI EN 60947-2
MODULAR SWITCH	CEI EN 60947-2
	CEI EN 60898
PANELBOARD	CEI EN 60439-1
DIMENSION COPPER BARS	
In=	250 [A]
Icc=	10,00[kA]

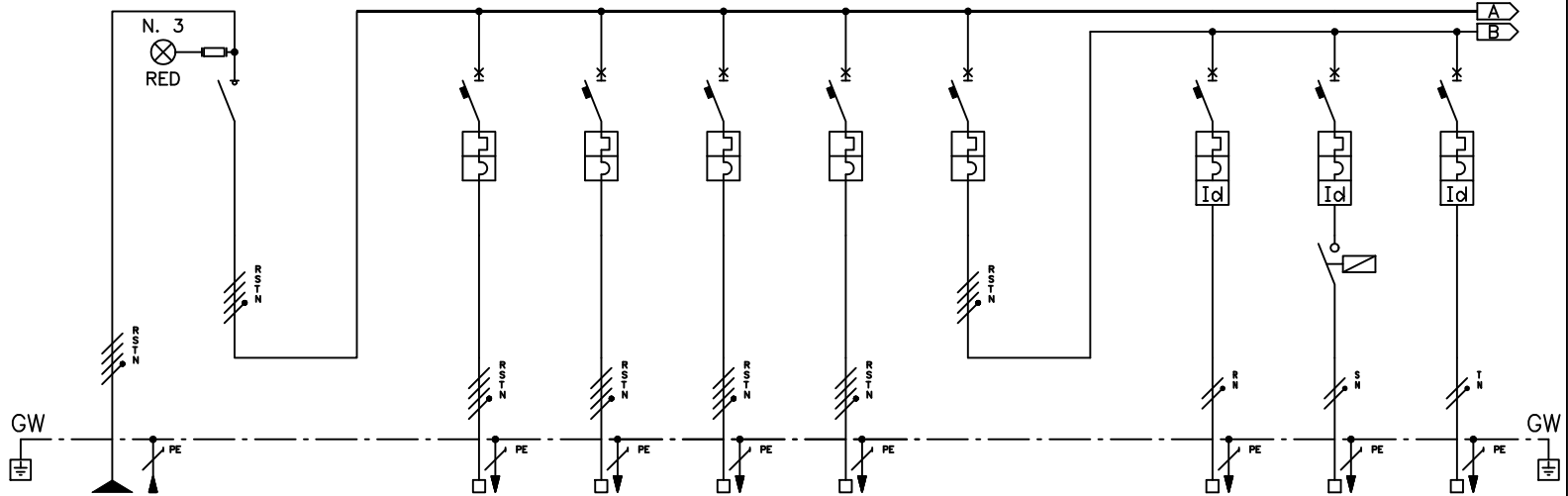

USER	SWITCH NAME	
	CIRCUIT NAME	
	DESCRIPTION OF THE CIRCUIT	
	INSTALLED ELECTRIC POWER	[kVA]
	INSTALLED ELECTRIC POWER	[kW]
	COEF. OF CONTEMPORANEITY	
	COEF. OF UTILISATION	
	USED ELECTRIC POWER	[kW]
	THREE OR MONO PHASE SYSTEM	
	VOLTAGE	[V]
Cos φ		
ELECTRICAL CURRENT USED	[A]	
DATA PANELBOARD	Icc ALLEGED	[kA]
SWITCH OR DISCONNECTOR	TYPE	
	SIZE	
	CHARACTERISTICS	
	MAGNETIC RELEASE I <sub>rm</sub>	[A]
	THERMAL RELEASE I <sub>rh</sub>	[A]
RESIDUAL CURRENT DEVICE	BREAKING CAPACITY	[kA]
	I <sub>Δn</sub>	[A]
	DELAY	[ms]
COMMAND DEVICE	TYPE	
	N. POLES x I <sub>n</sub>	[A]
THERMAL RELAY	THERMAL RELEASE I <sub>rh</sub>	[A]
FUSE	N. POLI x I <sub>n</sub>	[A]
CONNECTION	SIZE	[mm <sup>2</sup> ]
	SETTING	
	TYPE	
	NO. OF CORES X AREA	[mm <sup>2</sup> ]
	GROUND WIRE (GW)	[mm <sup>2</sup> ]
WIRE	NO. OF WIRE X POLE	
	LENGTH	[m]
	ΔV%	[%]
	CURRENT CARRYING CAPACITY	[A]
CHECK	MINIMUM Icc	[A]
	MAX Icc	[A]
	MAXIMUM LENGTH CHECKED	[m]

	Q1	Q2	Q3	Q4	Q5	Q6	Q7	Q8	Q9
	Main panel switch	PB1A	PB1B	PB1H A V C	Spare	Main lighting and sockets switch	Room 1.Z01-1.Z02/3 3.Z04/5	Stairs	Room 1.Z01-1.Z02/3 3.Z04/5
	144,60	26,28	32,83	81,25		4,25	1,11	1,00	1,88
	115,68	21,02	26,26	65,00		3,40	1,00	0,90	1,50
	1,00	1,00	1,00	1,00		1,00	1,00	1,00	1,00
	1,00	1,00	1,00	1,00		1,00	1,00	1,00	1,00
	115,68	21,02	26,26	65,00		3,40	1,00	0,90	1,50
	T	T	T	T		T	M	M	M
	380	380	380	380		380	220	220	220
	0,80	0,80	0,80	0,80		0,80	0,90	0,90	0,80
	219,7	39,9	49,9	123,5		6,5	5,1	4,5	8,5
	5,000	5,000	5,000	5,000	5,000	5,000	5,000	5,000	5,000
	Disconnector	Miniature	Miniature	moulded case	Miniature	Miniature	Miniature	Miniature	Miniature
	4x250	4x63	4x80	4x160	4x63	4x16	2x10	2x10	2x16
		C	C	C	C	C	C	C	C
		630	800	1.600	630	160	100	100	160
		63,0	80,0	160,0	63,0	16,0	10,0	10,0	16,0
		10,0	10,0	10,0	10,0	10,0	10,0	10,0	10,0
			3,400E+04	6,500E+04	#VALORE!	3,400E+04	1,200E+03	1,200E+03	1,200E+03
							0,03	0,03	0,03
								Latching	
								2x16	
		25	35	Direct			4	4	6
	FG7	B	B	B			B	B	B
	3x120+1x70	FG7	FG7	FG7			FG7	FG7	FG7
	1x70	5G16	5G25	3x70+1x35			3G2,5	3G2,5	3G4
				1x35					
		1	1	1			1	1	1
		40	50	50			30	30	30
		0,96	0,98	0,93			1,30	1,15	1,21
		89	117	222			31	31	42
		6,391E+06	1,560E+07	#VALORE!			1,560E+05	1,560E+05	3,994E+05
		1.620	1.923	2.916			355	355	568
		2.781	3.122	4.239			355	355	568
		111	136	128			107	107	107



PROJECT NAME S09\_04

PLANT INPUT	
FAULT CURRENT ALLEGED ON PANELBOARD	1,3 [KA]
RATED VOLTAGE	400 (V)
RATED FREQUENCY	50 (Hz)
SYSTEM OF NEUTRAL	TT
PANELBOARD NAME	
PB1A	
DP 31	SEGREGATION 3
NORMATIVE REFERENCE	
SWITCH	CEI EN 60947-2
MODULAR SWITCH	CEI EN 60947-2
	CEI EN 60898
PANELBOARD	CEI EN 60439-1
DIMENSION COPPER BARS	
In=	50 [A]    Icc= 6,00 [KA]

PANEL NAME  
Panelboard Building 1 – Floor A



















































CLIENT :

OBJECT

*Cathedral of Benghazi – Building 1*

TABLE: 06

# LEGEND SYMBOLS

SYMBOL	DESCRIPTION	SYMBOL	DESCRIPTION	SYMBOL	DESCRIPTION	SYMBOL	DESCRIPTION
	BATTERY ACCUMULATORI		PUSH SWITCH NO N.A.		CONTACTOR		METER
	RECTIFIER RADDRIZZATORE		PUSH SWITCH NC N.C.		PHASE WIRE		AMPEROMETRIC AND AMMETRIC SWITCH
	INVERTER C.C. - A.C.		SIGNAL LAMP		NEUTRAL WIRE		RELAY
	CONTROL ISOLATION "ISOLTESTER"		ELECTRIC SIREN		EXTRACTABLE SWITCH		DELAY TO DISEXCITATION RELAY
	AUXILIARY CONTACT NO		FUSE		SAFETY ISOLATING TRASFORMERS		DELAY TO EXCITATION RELAY
	AUXILIARY CONTACT NC		DIODE		TRANSFORMER		TWILIGHT SWITCH
	AUXILIARY CONTACT OF THERMAL RELAY NO		AUTOMATIC CIRCUIT BREAKER		RIDUTTORE DI CORRENTE (TA)		THREE PHASE MOTOR A.C.
	AUXILIARY CONTACT OF THERMAL RELAY NC		ISOLATOR		EARTH CONNECTION		MONO PHASE MOTOR A.C.
	AUXILIARY CONTACT TIMED TO THE EXCITATION NO		MAGNETIC AND THERMAL SWITCH		KEY LOCK		THREE PHASE CAPACITOR
	AUXILIARY CONTACT TIMED TO THE EXCITATION NC		MAGNETIC, THERMAL AND RESIDUAL CURRENT SWITCH		LOCK		
	AUXILIARY CONTACT TIMED TO THE DISEXCITATION NO		RESIDUAL CURRENT SWITCH		TIME SWITCH		
	AUXILIARY CONTACT TIMED TO THE DISEXCITATION NC		SWITCH		TERMINAL		
	PROXIMITY SWITCH NO		FUSE-DISCONNECTOR		VOLTMETER		
	PROXIMITY SWITCH NC		EARTHING SWITCH		AMPEROMETER		

PROJECT NAME S09\_04

PLANT INPUT	
FAULT CURRENT ALLEGED ON PANELBOARD	1,3 [kA]
RATED VOLTAGE	400 (V)
RATED FREQUENCY	50 (Hz)
SYSTEM OF NEUTRAL	TT
PANELBOARD NAME	
PB1A	
DP 31	SEGREGATION 3
NORMATIVE REFERENCE	
SWITCH	CEI EN 60947-2
MODULAR SWITCH	CEI EN 60947-2
	CEI EN 60898
PANELBOARD	CEI EN 60439-1
DIMENSION COPPER BARS	
$I_n =$	50 [A]
$I_{cc} =$	6,00 [kA]

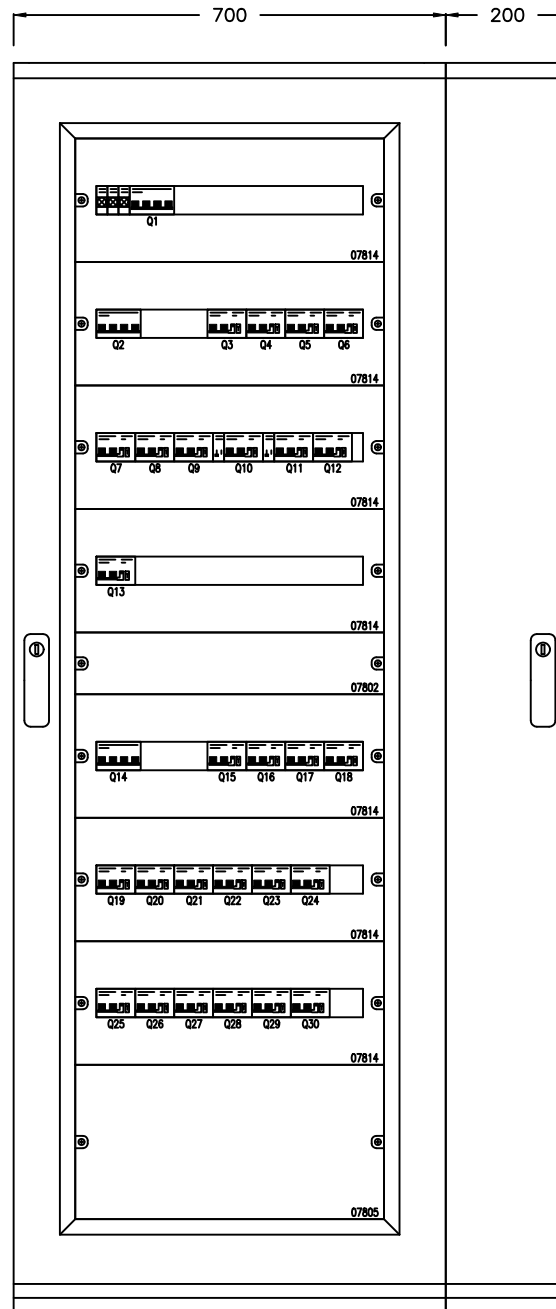

DIMENSION PANEL

HEIGHT [mm] : 2.000 BREADTH [mm] : 900 DEPTH [mm] : 400



REFERENCE NUMBER OF DEVICE	1	2	3	4	5	6	7	8	9	10	11	12
PROJECT NAME	SO9_04											

PLANT INPUT	
FAULT CURRENT ALLEGED ON PANELBOARD	1,3 [kA]
RATED VOLTAGE	400 (V)
RATED FREQUENCY	50 (Hz)
SYSTEM OF NEUTRAL	TT
PANELBOARD NAME	
PB1A	
DP 31	SEGREGATION 3
NORMATIVE REFERENCE	
SWITCH	CEI EN 60947-2
MODULAR SWITCH	CEI EN 60947-2
	CEI EN 60898
PANELBOARD	CEI EN 60439-1
DIMENSION COPPER BARS	
In=	50 [A]
Icc=	6,00 [kA]

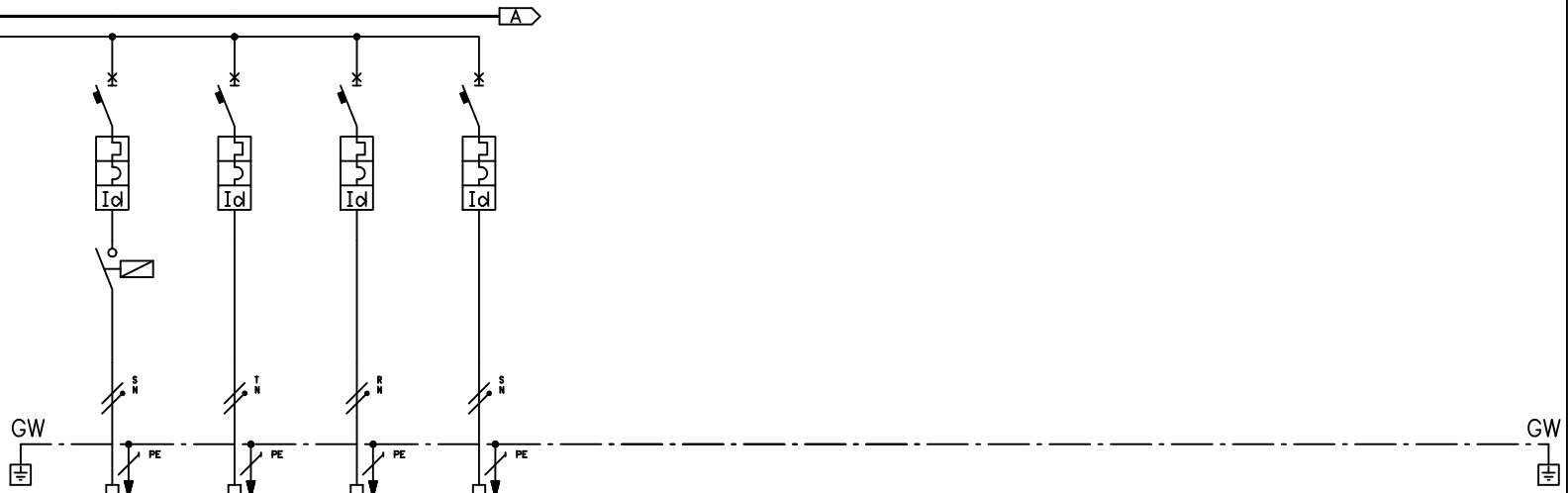

USER	SWITCH NAME	
	CIRCUIT NAME	
	DESCRIPTION OF THE CIRCUIT	
	INSTALLED ELECTRIC POWER	[kVA]
	INSTALLED ELECTRIC POWER	[kW]
	COEF. OF CONTEMPORANEITY	
	COEF. OF UTILISATION	
	USED ELECTRIC POWER	[kW]
	THREE OR MONO PHASE SYSTEM	
	VOLTAGE	[V]
	Cos φ	
	ELECTRICAL CURRENT USED	[A]
DATA PANELBOARD	Icc ALLEGED	[kA]
SWITCH OR DISCONNECTOR	TYPE	
	SIZE	
	CHARACTERISTICS	
	MAGNETIC RELEASE I <sub>rm</sub>	[A]
	THERMAL RELEASE I <sub>rth</sub>	[A]
RESIDUAL CURRENT DEVICE	BREAKING CAPACITY	[kA]
	I <sub>Δt</sub>	[A²s]
	RATED SENSITIVITY	[A]
COMMAND DEVICE	DELAY	[ms]
	TYPE	
THERMAL RELAY	N. POLES x I <sub>n</sub>	[A]
	THERMAL RELEASE I <sub>rth</sub>	[A]
FUSE	N. POLI x I <sub>n</sub>	[A]
	SIZE	[mm²]
WIRE	CONNECTION	
	SETTING	
	TYPE	
	NO. OF CORES X AREA	[mm²]
	GROUND WIRE (GW)	[mm²]
CHECK	NO. OF WIRE X POLE	
	LENGTH	[m]
	ΔV%	[%]
	CURRENT CARRYING CAPACITY	[A]
	MINIMUM Icc	[A]
WIRE	MAX Icc	[A]
	MAXIMUM LENGTH CHECKED	[m]

Q10	Q11	Q12	Q13									
L8	L9											
Stairs	Emergency Lighting	Spare	Spare									
0,28	0,10											
0,25	0,09											
1,00	1,00											
1,00	1,00											
0,25	0,09											
M	M											
220	220											
0,90	0,90											
1,3	0,5											
1,300	1,300	1,300	1,300	1,300	1,300	1,300	1,300	1,300	1,300	1,300	1,300	1,300
Miniature	Miniature	Miniature	Miniature									
2x6	2x6	2x10	2x10									
C	C	C	C									
60	60	100	100									
6,0	6,0	10,0	10,0									
6,0	6,0	6,0	6,0									
3,660E+03	3,660E+03	4,860E+03	4,860E+03									
0,03	0,03	0,03	0,03									
Latching												
2x16												
4	4											
B	B											
FG7	FG7											
3G2,5	3G2,5											
1	1											
15	30											
0,17	0,13											
31	31											
1,560E+05	1,560E+05											
621	342											
621	342											
176	176											



REFERENCE NUMBER OF DEVICE	1	2	3	4	5	6	7	8	9	10	11	12
PROJECT NAME	S09_04											

PLANT INPUT	
FAULT CURRENT ALLEGED ON PANELBOARD	1,3 [kA]
RATED VOLTAGE	400 (V)
RATED FREQUENCY	50 (Hz)
SYSTEM OF NEUTRAL	TT
PANELBOARD NAME	
PB1A	
DP 31	SEGREGATION 3
NORMATIVE REFERENCE	
SWITCH	CEI EN 60947-2
MODULAR SWITCH	CEI EN 60947-2
	CEI EN 60898
PANELBOARD	CEI EN 60439-1
DIMENSION COPPER BARS	
In=	50 [A]
Icc=	6,00 [kA]

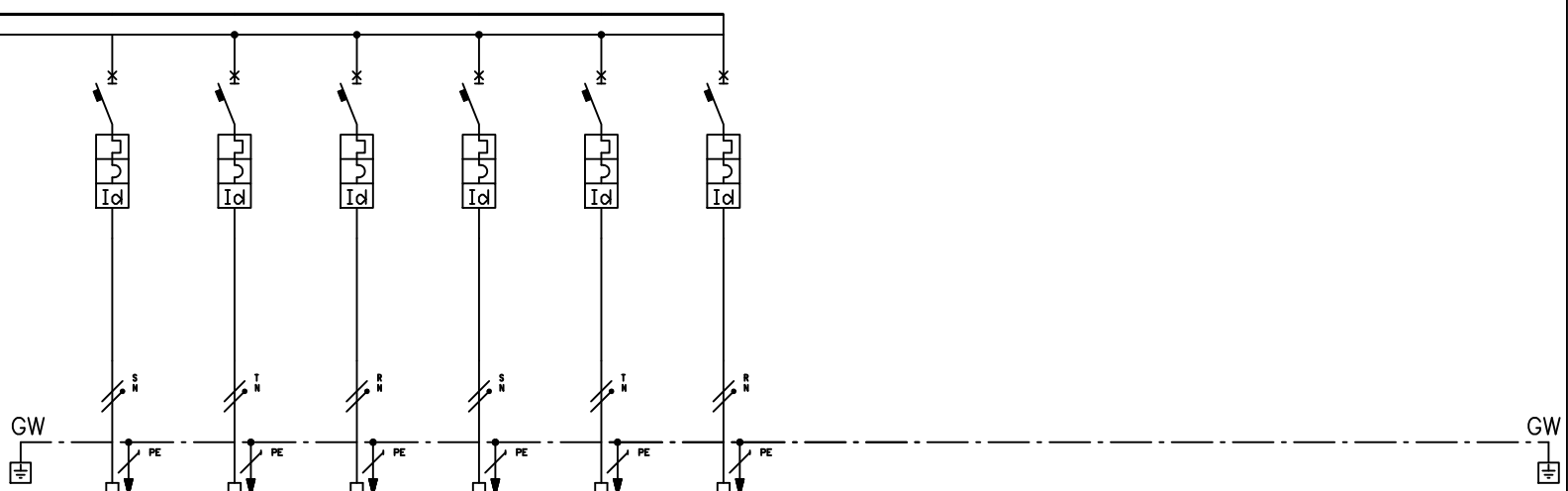

USER	SWITCH NAME	
	CIRCUIT NAME	
	DESCRIPTION OF THE CIRCUIT	
	INSTALLED ELECTRIC POWER	[kVA]
	INSTALLED ELECTRIC POWER	[kW]
	COEF. OF CONTEMPORANEITY	
	COEF. OF UTILISATION	
	USED ELECTRIC POWER	[kW]
	THREE OR MONO PHASE SYSTEM	
	VOLTAGE	[V]
	Cos φ	
	ELECTRICAL CURRENT USED	[A]
DATA PANELBOARD	Icc ALLEGED	[kA]
	TYPE	
SWITCH OR DISCONNECTOR	SIZE	
	CHARACTERISTICS	
	MAGNETIC RELEASE I <sub>rm</sub>	[A]
	THERMAL RELEASE I <sub>rh</sub>	[A]
	BREAKING CAPACITY	[kA]
RESIDUAL CURRENT DEVICE	I <sub>Δn</sub>	[A]
	DELAY	[ms]
COMMAND DEVICE	TYPE	
	N. POLES x I <sub>n</sub>	[A]
THERMAL RELAY	THERMAL RELEASE I <sub>rh</sub>	[A]
FUSE	N. POLI x I <sub>n</sub>	[A]
CONNECTION	SIZE	[mm <sup>2</sup> ]
	SETTING	
	TYPE	
	NO. OF CORES X AREA	[mm <sup>2</sup> ]
	GROUND WIRE (GW)	[mm <sup>2</sup> ]
WIRE	NO. OF WIRE X POLE	
	LENGTH	[m]
	ΔV%	[%]
	CURRENT CARRYING CAPACITY	[A]
CHECK	WIRE	[A <sup>2</sup> t]
	MINIMUM Icc	[A]
	MAX Icc	[A]
	MAXIMUM LENGTH CHECKED	[m]

Q25	Q26	Q27	Q28	Q29	Q30							
FM11												
1.A 07-1.A 10 1.A 15-1.A 16 1.A 17 - stairs	Video entryphone	Rack Data	Panel for fire alarm	Spare	Spare							
1,88	0,38	1,00	0,25									
1,50	0,30	0,80	0,20									
1,00	1,00	1,00	1,00									
1,00	1,00	1,00	1,00									
1,50	0,30	0,80	0,20									
M	M	M	M									
220	220	220	220									
0,80	0,80	0,80	0,80									
8,5	1,7	4,5	1,1									
1,300	1,300	1,300	1,300	1,300	1,300	1,300	1,300	1,300	1,300	1,300	1,300	1,300
Miniature	Miniature	Miniature	Modulare	Miniature	Miniature							
2x16	2x16	2x16	2x10	2x16	2x16							
C	C	C	C	C	C							
160	160	160	100	160	160							
16,0	16,0	16,0	10,0	16,0	16,0							
6,0	6,0	6,0	6,0	6,0	6,0							
4,860E+03	4,860E+03	4,860E+03	4,860E+03	4,860E+03	4,860E+03							
0,03	0,03	0,03	0,03	0,03	0,03							
6	6	6	4									
B	B	B	B									
FG7	FG7	FG7	FG7									
3G4	3G4	3G4	3G2,5									
1	1	1	1									
30	40	10	10									
1,21	0,32	0,21	0,08									
42	42	42	31									
3,994E+05	3,994E+05	3,994E+05	1,560E+05									
520	405	1,026	819									
520	405	1,026	819									
107	107	107	106									

PROJECT NAME S09\_04

PLANT INPUT	
FAULT CURRENT ALLEGED ON PANELBOARD	1,3 [KA]
RATED VOLTAGE	400 (V)
RATED FREQUENCY	50 (Hz)
SYSTEM OF NEUTRAL	TT
PANELBOARD NAME	
PB1B	
DP 31	SEGREGATION 3
NORMATIVE REFERENCE	
SWITCH	CEI EN 60947-2
MODULAR SWITCH	CEI EN 60947-2
	CEI EN 60898
PANELBOARD	CEI EN 60439-1
DIMENSION COPPER BARS	
In=	63 [A]    Icc= 6,00 [KA]

PANEL NAME  
Panelboard Building 1 – Floor B



















































CLIENT :

OBJECT

*Cathedral of Benghazi – Building 1*

TABLE: 07

# LEGEND SYMBOLS

SYMBOL	DESCRIPTION	SYMBOL	DESCRIPTION	SYMBOL	DESCRIPTION	SYMBOL	DESCRIPTION
	BATTERY ACCUMULATORI		PUSH SWITCH NO N.A.		CONTACTOR		METER
	RECTIFIER RADDRIZZATORE		PUSH SWITCH NC N.C.		PHASE WIRE		AMPEROMETRIC AND AMMETRIC SWITCH
	INVERTER C.C. - A.C.		SIGNAL LAMP		NEUTRAL WIRE		RELAY
	CONTROL ISOLATION "ISOLTESTER"		ELECTRIC SIREN		EXTRACTABLE SWITCH		DELAY TO DISEXCITATION RELAY
	AUXILIARY CONTACT NO		FUSE		SAFETY ISOLATING TRASFORMERS		DELAY TO EXCITATION RELAY
	AUXILIARY CONTACT NC		DIODE		TRANSFORMER		TWILIGHT SWITCH
	AUXILIARY CONTACT OF THERMAL RELAY NO		AUTOMATIC CIRCUIT BREAKER		RIDUTTORE DI CORRENTE (TA)		THREE PHASE MOTOR A.C.
	AUXILIARY CONTACT OF THERMAL RELAY NC		ISOLATOR		EARTH CONNECTION		MONO PHASE MOTOR A.C.
	AUXILIARY CONTACT TIMED TO THE EXCITATION NO		MAGNETIC AND THERMAL SWITCH		KEY LOCK		THREE PHASE CAPACITOR
	AUXILIARY CONTACT TIMED TO THE EXCITATION NC		MAGNETIC, THERMAL AND RESIDUAL CURRENT SWITCH		LOCK		
	AUXILIARY CONTACT TIMED TO THE DISEXCITATION NO		RESIDUAL CURRENT SWITCH		TIME SWITCH		
	AUXILIARY CONTACT TIMED TO THE DISEXCITATION NC		SWITCH		TERMINAL		
	PROXIMITY SWITCH NO		FUSE-DISCONNECTOR		VOLTMETER		
	PROXIMITY SWITCH NC		EARTHING SWITCH		AMPEROMETER		

PROJECT NAME S09\_04

PLANT INPUT	
FAULT CURRENT ALLEGED ON PANELBOARD	1,3 [KA]
RATED VOLTAGE	400 (V)
RATED FREQUENCY	50 (Hz)
SYSTEM OF NEUTRAL	TT
PANELBOARD NAME	
PB1B	
DP 31	SEGREGATION 3
NORMATIVE REFERENCE	
SWITCH	CEI EN 60947-2
MODULAR SWITCH	CEI EN 60947-2
	CEI EN 60898
PANELBOARD	CEI EN 60439-1
DIMENSION COPPER BARS	
$I_n = 63$ [A]	$I_{cc} = 6,00$ [KA]

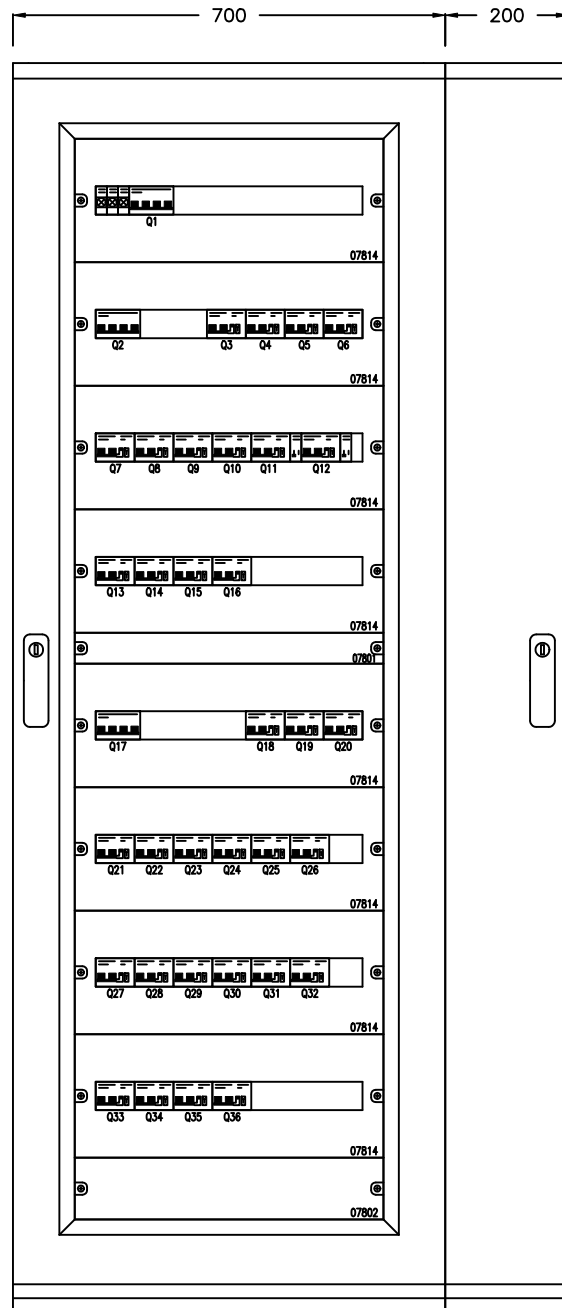

DIMENSION PANEL

HEIGHT [mm] : 2.000 BREADTH [mm] : 900 DEPTH [mm] : 400



REFERENCE NUMBER OF DEVICE	1	2	3	4	5	6	7	8	9	10	11	12
PROJECT NAME	S09_04											

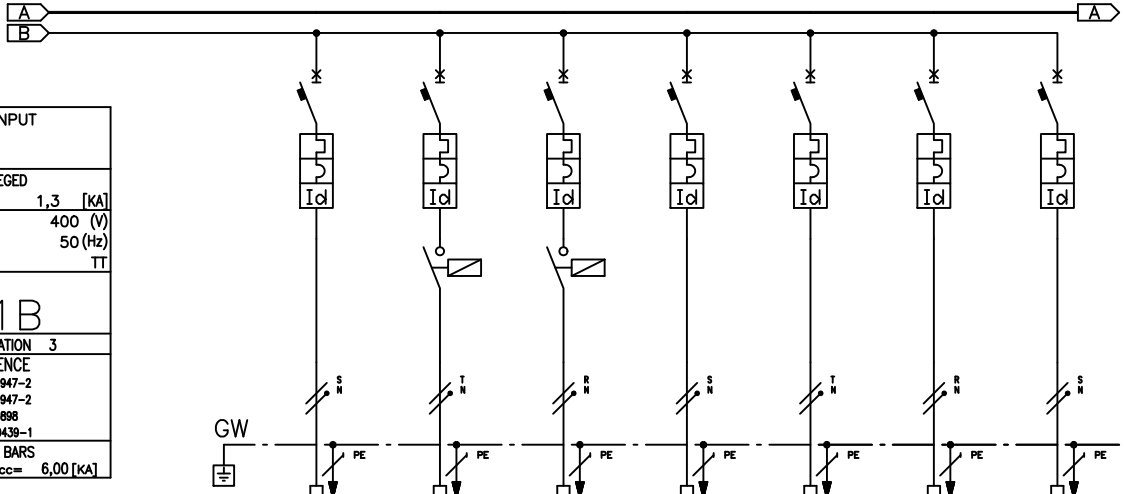

PLANT INPUT	
FAULT CURRENT ALLEGED ON PANELBOARD	1,3 [kA]
RATED VOLTAGE	400 (V)
RATED FREQUENCY	50 (Hz)
SYSTEM OF NEUTRAL	TT
PANELBOARD NAME	
PB1B	
DP 31	SEGREGATION 3
NORMATIVE REFERENCE	
SWITCH	CEI EN 60947-2
MODULAR SWITCH	CEI EN 60947-2
	CEI EN 60898
PANELBOARD	CEI EN 60439-1
DIMENSION COPPER BARS	
In=	63 [A]
Icc=	6,00 [kA]

USER	SWITCH NAME	
	CIRCUIT NAME	
	DESCRIPTION OF THE CIRCUIT	
	INSTALLED ELECTRIC POWER	[kVA]
	INSTALLED ELECTRIC POWER	[kW]
	COEF. OF CONTEMPORANEITY	
	COEF. OF UTILISATION	
	USED ELECTRIC POWER	[kW]
	THREE OR MONO PHASE SYSTEM	
	VOLTAGE	[V]
Cos φ		
ELECTRICAL CURRENT USED	[A]	
DATA PANELBOARD	Icc ALLEGED	[kA]
	TYPE	
SWITCH OR DISCONNECTOR	SIZE	
	CHARACTERISTICS	
	MAGNETIC RELEASE I <sub>rm</sub>	[A]
	THERMAL RELEASE I <sub>rh</sub>	[A]
	BREAKING CAPACITY	[kA]
I <sub>∞t</sub>	[A²t]	
RESIDUAL CURRENT DEVICE	RATED SENSITIVITY	[A]
	DELAY	[ms]
COMMAND DEVICE	TYPE	
	N. POLES x In	[A]
THERMAL RELAY	THERMAL RELEASE I <sub>rh</sub>	[A]
FUSE	N. POLI x In	[A]
CONNECTION	SIZE	[mm²]
	SETTING	
	TYPE	
	NO. OF CORES X AREA	[mm²]
	GROUND WIRE (GW)	[mm²]
WIRE	NO. OF WIRE X POLE	
	LENGTH	[m]
	ΔV%	[%]
	CURRENT CARRYING CAPACITY	[A]
CHECK	MINIMUM Icc	[A]
	MAX Icc	[A]
	MAXIMUM LENGTH CHECKED	[m]

Q10	Q11	Q12	Q13	Q14	Q15	Q16						
L8	L9	L10	L11	L12								
Baths 1.B23	1.B05-1.B09 1.B15-1.B19	Stairs	Emergency Lighting	Window s	Spare	Spare						
0,33	0,78	0,11	0,08	0,22								
0,30	0,70	0,10	0,07	0,20								
1,00	1,00	1,00	1,00	1,00								
1,00	1,00	1,00	1,00	1,00								
0,30	0,70	0,10	0,07	0,20								
M	M	M	M	M								
220	220	220	220	220								
0,90	0,90	0,90	0,90	0,90								
1,5	3,5	0,5	0,4	1,0								
1,300	1,300	1,300	1,300	1,300	1,300	1,300	1,300	1,300	1,300	1,300	1,300	1,300
Miniature	Miniature	Miniature	Miniature	Miniature	Miniature	Miniature						
2x10	2x10	2x6	2x6	2x6	2x10	2x10						
C	C	C	C	C	C	C						
100	100	60	60	60	100	100						
10,0	10,0	6,0	6,0	6,0	10,0	10,0						
6,0	6,0	6,0	6,0	6,0	6,0	6,0						
4,860E+03	4,860E+03	3,660E+03	3,660E+03	3,660E+03	4,860E+03	4,860E+03						
0,03	0,03	0,03	0,03	0,03	0,03	0,03						
	Latching	Latching										
	2x16	2x16										
4	4	4	4	4								
B	B	B	B	B								
FG7	FG7	FG7	FG7	FG7								
3G2,5	3G2,5	3G2,5	3G2,5	3G2,5								
1	1	1	1	1								
50	20	15	30	50								
0,64	0,59	0,06	0,10	0,42								
31	31	31	31	31								
1,560E+05	1,560E+05	1,560E+05	1,560E+05	1,560E+05								
210	491	621	342	210								
210	491	621	342	210								
106	106	176	176	176								



REFERENCE NUMBER OF DEVICE	1	2	3	4	5	6	7	8	9	10	11	12
PROJECT NAME	SO9_04											

PLANT INPUT	
FAULT CURRENT ALLEGED ON PANELBOARD	1,3 [kA]
RATED VOLTAGE	400 (V)
RATED FREQUENCY	50 (Hz)
SYSTEM OF NEUTRAL	TT
PANELBOARD NAME	
PB1B	
DP 31	SEGREGATION 3
NORMATIVE REFERENCE	
SWITCH	CEI EN 60947-2
MODULAR SWITCH	CEI EN 60947-2
	CEI EN 60898
PANELBOARD	CEI EN 60439-1
DIMENSION COPPER BARS	
In=	63 [A]
Icc=	6,00 [kA]

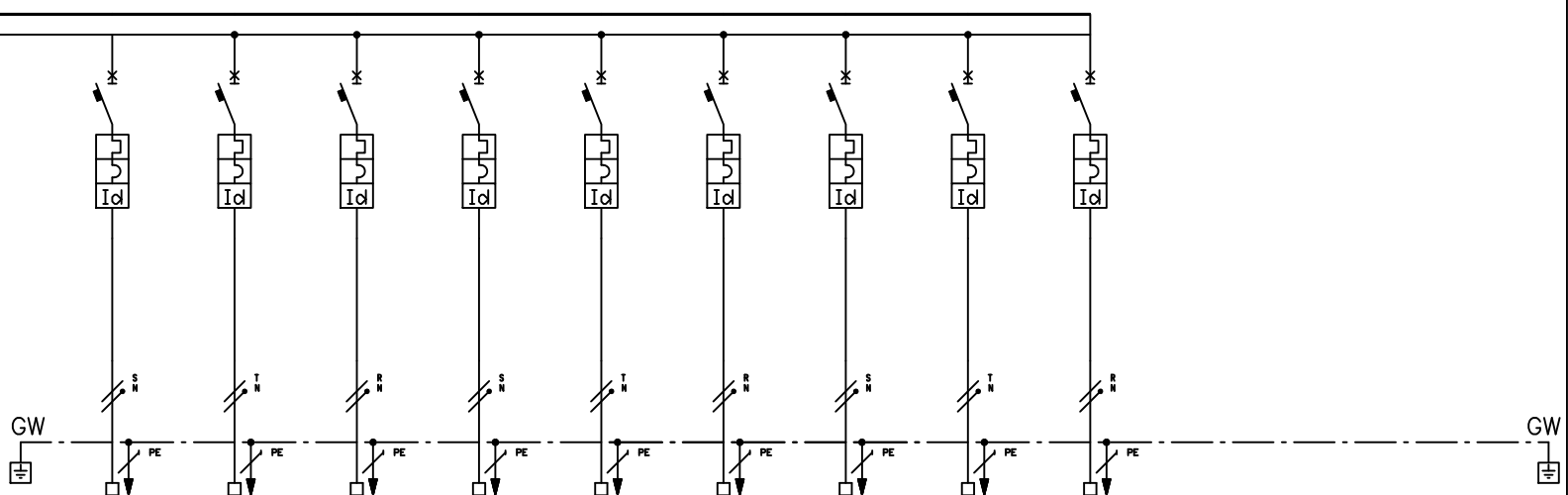

USER	SWITCH NAME	
	CIRCUIT NAME	
	DESCRIPTION OF THE CIRCUIT	
	INSTALLED ELECTRIC POWER	[kVA]
	INSTALLED ELECTRIC POWER	[kW]
	COEF. OF CONTEMPORANEITY	
	COEF. OF UTILISATION	
	USED ELECTRIC POWER	[kW]
	THREE OR MONO PHASE SYSTEM	
	VOLTAGE	[V]
Cos φ		
ELECTRICAL CURRENT USED	[A]	
DATA PANELBOARD	Icc ALLEGED	[kA]
	TYPE	
SWITCH OR DISCONNECTOR	SIZE	
	CHARACTERISTICS	
	MAGNETIC RELEASE I <sub>rm</sub>	[A]
	THERMAL RELEASE I <sub>rh</sub>	[A]
	BREAKING CAPACITY	[kA]
I <sub>∞t</sub>	[A <sup>2</sup> t]	
RESIDUAL CURRENT DEVICE	RATED SENSITIVITY	[A]
	DELAY	[ms]
COMMAND DEVICE	TYPE	
	N. POLES x In	[A]
THERMAL RELAY	THERMAL RELEASE I <sub>rh</sub>	[A]
FUSE	N. POLI x In	[A]
CONNECTION	SIZE	[mm <sup>2</sup> ]
	SETTING	
WIRE	TYPE	
	NO. OF CORES X AREA	[mm <sup>2</sup> ]
	GROUND WIRE (GW)	[mm <sup>2</sup> ]
	NO. OF WIRE X POLE	
	LENGTH	[m]
	ΔV%	[%]
CHECK	CURRENT CARRYING CAPACITY	[A]
	k <sup>2</sup> s <sup>2</sup>	[A <sup>2</sup> t]
WIRE	MINIMUM Icc	[A]
	MAX Icc	[A]
	MAXIMUM LENGTH CHECKED	[m]

Q28	Q29	Q30	Q31	Q32	Q33	Q34	Q35	Q36				
FM11	FM12	FM13	FM14	FM15	FM16							
Room 1.B12	Room 1.B10	Room 1.B02	Room 1.B01	Baths 1.B23	1.B05-1.B09 1.B19- stairs	Rack Data	Spare	Spare				
1,50	2,13	2,25	2,00	0,88	0,75	1,00						
1,20	1,70	1,80	1,60	0,70	0,60	0,80						
1,00	1,00	1,00	1,00	1,00	1,00	1,00						
1,00	1,00	1,00	1,00	1,00	1,00	1,00						
1,20	1,70	1,80	1,60	0,70	0,60	0,80						
M	M	M	M	M	M	M						
220	220	220	220	220	220	220						
0,80	0,80	0,80	0,80	0,80	0,80	0,80						
6,8	9,7	10,2	9,1	4,0	3,4	4,5						
1,300	1,300	1,300	1,300	1,300	1,300	1,300	1,300	1,300	1,300	1,300	1,300	1,300
Miniature	Miniature	Miniature	Miniature	Miniature	Miniature	Miniature	Miniature	Miniature	Miniature			
2x16	2x16	2x16	2x16	2x16	2x16	2x16	2x16	2x16	2x16			
C	C	C	C	C	C	C	C	C	C			
160	160	160	160	160	160	160	160	160	160			
16,0	16,0	16,0	16,0	16,0	16,0	16,0	16,0	16,0	16,0			
6,0	6,0	6,0	6,0	6,0	6,0	6,0	6,0	6,0	6,0			
4,860E+03	4,860E+03	4,860E+03	4,860E+03	4,860E+03	4,860E+03	4,860E+03	4,860E+03	4,860E+03	4,860E+03			
0,03	0,03	0,03	0,03	0,03	0,03	0,03	0,03	0,03	0,03			
6	6	6	6	6	6	6						
B	B	B	B	B	B	B						
FG7	FG7	FG7	FG7	FG7	FG7	FG7						
3G4	3G4	3G4	3G4	3G4	3G4	3G4						
1	1	1	1	1	1	1						
30	40	40	40	50	20	10						
0,97	1,84	1,93	1,72	0,95	0,32	0,21						
42	42	42	42	42	42	42						
3,994E+05	3,994E+05	3,994E+05	3,994E+05	3,994E+05	3,994E+05	3,994E+05						
520	405	405	405	330	710	1,026						
520	405	405	405	330	710	1,026						
107	107	107	107	107	107	107						

PROJECT NAME S09\_04

PLANT INPUT	
FAULT CURRENT ALLEGED ON PANELBOARD	5,00 [kA]
RATED VOLTAGE	400 (V)
RATED FREQUENCY	50 (Hz)
SYSTEM OF NEUTRAL	TT
PANELBOARD NAME	
PB5Z	
DP 31	SEGREGATION 3
NORMATIVE REFERENCE	
SWITCH	CEI EN 60947-2
MODULAR SWITCH	CEI EN 60947-2
	CEI EN 60898
PANELBOARD	CEI EN 60439-1
DIMENSION COPPER BARS	
In=	160 [A]    Icc= 10,00[kA]

PANEL NAME  
Panelboard Building 5 – floor Z



















































CLIENT :

OBJECT :

*Cathedral of Benghazi – Building 5*

TABLE: 08

# LEGEND SYMBOLS

SYMBOL	DESCRIPTION	SYMBOL	DESCRIPTION	SYMBOL	DESCRIPTION	SYMBOL	DESCRIPTION
	BATTERY ACCUMULATORI		PUSH SWITCH NO N.A.		CONTACTOR		METER
	RECTIFIER RADDRIZZATORE		PUSH SWITCH NC N.C.		PHASE WIRE		AMPEROMETRIC AND AMMETRIC SWITCH
	INVERTER C.C. - A.C.		SIGNAL LAMP		NEUTRAL WIRE		RELAY
	CONTROL ISOLATION "ISOLTESTER"		ELECTRIC SIREN		EXTRACTABLE SWITCH		DELAY TO DISEXCITATION RELAY
	AUXILIARY CONTACT NO		FUSE		SAFETY ISOLATING TRASFORMERS		DELAY TO EXCITATION RELAY
	AUXILIARY CONTACT NC		DIODE		TRANSFORMER		TWILIGHT SWITCH
	AUXILIARY CONTACT OF THERMAL RELAY NO		AUTOMATIC CIRCUIT BREAKER		RIDUTTORE DI CORRENTE (TA)		THREE PHASE MOTOR A.C.
	AUXILIARY CONTACT OF THERMAL RELAY NC		ISOLATOR		EARTH CONNECTION		MONO PHASE MOTOR A.C.
	AUXILIARY CONTACT TIMED TO THE EXCITATION NO		MAGNETIC AND THERMAL SWITCH		KEY LOCK		THREE PHASE CAPACITOR
	AUXILIARY CONTACT TIMED TO THE EXCITATION NC		MAGNETIC, THERMAL AND RESIDUAL CURRENT SWITCH		LOCK		
	AUXILIARY CONTACT TIMED TO THE DISEXCITATION NO		RESIDUAL CURRENT SWITCH		TIME SWITCH		
	AUXILIARY CONTACT TIMED TO THE DISEXCITATION NC		SWITCH		TERMINAL		
	PROXIMITY SWITCH NO		FUSE-DISCONNECTOR		VOLTMETER		
	PROXIMITY SWITCH NC		EARTHING SWITCH		AMPEROMETER		

PROJECT NAME S09\_04

PLANT INPUT	
FAULT CURRENT ALLEGED ON PANELBOARD	5,00 [kA]
RATED VOLTAGE	400 (V)
RATED FREQUENCY	50 (Hz)
SYSTEM OF NEUTRAL	TT
PANELBOARD NAME	
PB5Z	
DP 31	SEGREGATION 3
NORMATIVE REFERENCE	
SWITCH	CEI EN 60947-2
MODULAR SWITCH	CEI EN 60947-2
	CEI EN 60898
PANELBOARD	CEI EN 60439-1
DIMENSION COPPER BARS	
$I_n = 160$ [A]	$I_{cc} = 10,00$ [kA]

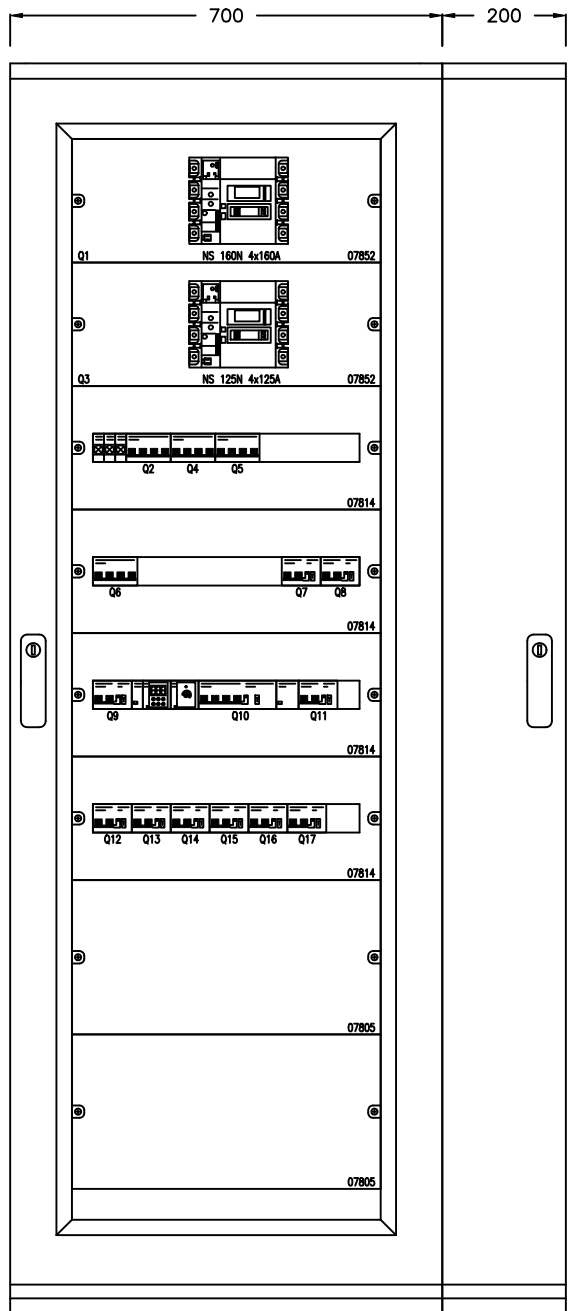

DIMENSION PANEL			
HEIGHT [mm] :	2.000	BREADTH [mm] :	900
		DEPTH [mm] :	400

REFERENCE NUMBER OF DEVICE	1	2	3	4	5	6	7	8	9	10	11	12
PROJECT NAME	S09_04											

PLANT INPUT	
FAULT CURRENT ALLEGED ON PANELBOARD	5,00 [kA]
RATED VOLTAGE	400 (V)
RATED FREQUENCY	50 (Hz)
SYSTEM OF NEUTRAL	TT
PANELBOARD NAME	PB5Z
DP 31 SEGREGATION	3
NORMATIVE REFERENCE	
SWITCH	CEI EN 60947-2
MODULAR SWITCH	CEI EN 60947-2
	CEI EN 60898
PANELBOARD	CEI EN 60439-1
DIMENSION COPPER BARS	
In=	160 [A]
Icc=	10,00[kA]

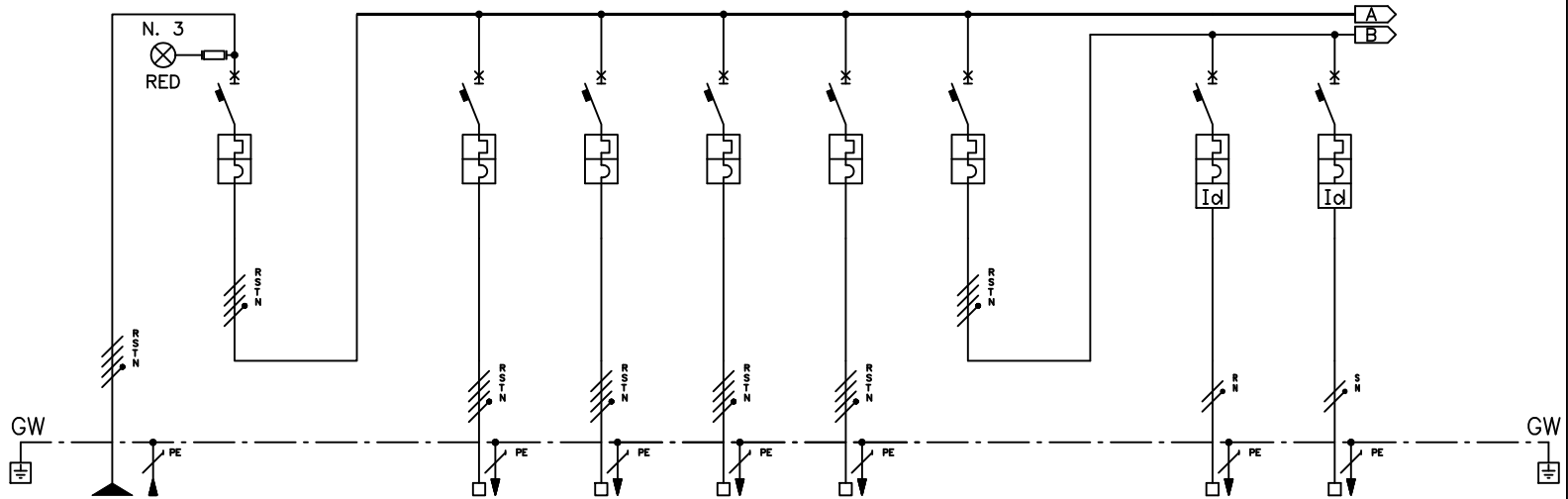

USER	SWITCH NAME	
	CIRCUIT NAME	
	DESCRIPTION OF THE CIRCUIT	
	INSTALLED ELECTRIC POWER	[kVA]
	INSTALLED ELECTRIC POWER	[kW]
	COEF. OF CONTEMPORANEITY	
	COEF. OF UTILISATION	
	USED ELECTRIC POWER	[kW]
	THREE OR MONO PHASE SYSTEM	
	VOLTAGE	[V]
Cos φ		
ELECTRICAL CURRENT USED	[A]	
DATA PANELBOARD	Icc ALLEGED	[kA]
SWITCH OR DISCONNECTOR	TYPE	
	SIZE	
	CHARACTERISTICS	
	MAGNETIC RELEASE I <sub>rm</sub>	[A]
	THERMAL RELEASE I <sub>rh</sub>	[A]
	BREAKING CAPACITY	[kA]
RESIDUAL CURRENT DEVICE	I <sub>Δn</sub>	[A]
	DELAY	[ms]
COMMAND DEVICE	TYPE	
	N. POLES x I <sub>n</sub>	[A]
THERMAL RELAY	THERMAL RELEASE I <sub>rh</sub>	[A]
FUSE	N. POLI x I <sub>n</sub>	[A]
CONNECTION	SIZE	[mm <sup>2</sup> ]
	SETTING	
	TYPE	
	NO. OF CORES X AREA	[mm <sup>2</sup> ]
	GROUND WIRE (GW)	[mm <sup>2</sup> ]
WIRE	NO. OF WIRE X POLE	
	LENGTH	[m]
	ΔV%	[%]
	CURRENT CARRYING CAPACITY	[A]
CHECK	MINIMUM Icc	[A]
	MAX Icc	[A]
	MAXIMUM LENGTH CHECKED	[m]

	Q1	Q2	Q3	Q4	Q5	Q6	Q7	Q8
	Main panel switch	PB5A	PC	PB5H A V C	Spare	Main lighting and sockets switch	L1 Room 5.Z01 - 5.Z02 5.Z03	L2 Baths
INSTALLED ELECTRIC POWER	70,31	3,15	49,81	7,50		8,76	1,27	0,38
INSTALLED ELECTRIC POWER	56,25	2,52	39,85	6,00		7,88	1,14	0,34
COEF. OF CONTEMPORANEITY	1,00	1,00	1,00	1,00		1,00	1,00	1,00
COEF. OF UTILISATION	1,00	1,00	1,00	1,00		1,00	1,00	1,00
USED ELECTRIC POWER	56,25	2,52	39,85	6,00		7,88	1,14	0,34
THREE OR MONO PHASE SYSTEM	T	T	T	T		T	M	M
VOLTAGE	380	380	380	380		380	220	220
Cos φ	0,80	0,80	0,80	0,80		0,90	0,90	0,90
ELECTRICAL CURRENT USED	106,8	4,8	75,7	11,4		13,3	5,8	1,7
Icc ALLEGED	5,000	5,000	5,000	5,000	5,000	5,000	5,000	5,000
TYPE	moulded case	Miniature	moulded case	Miniature	Miniature	Miniature	Miniature	Miniature
SIZE	4x160	4x20	4x125	4x32	4x32	4x25	2x10	2x10
CHARACTERISTICS	C	C	C	C	C	C	C	C
MAGNETIC RELEASE I <sub>rm</sub>	1.600	200	1.250	320	320	250	100	100
THERMAL RELEASE I <sub>rh</sub>	160,0	20,0	125,0	32,0	32,0	25,0	10,0	10,0
BREAKING CAPACITY	10,0	10,0	10,0	10,0	10,0	10,0	10,0	10,0
I <sub>Δn</sub>	2,200E+05	1,200E+03	2,200E+05	1,600E+04	1,600E+04	1,600E+04	1,200E+03	1,200E+03
RATED SENSITIVITY							0,03	0,03
DELAY								
TYPE								
N. POLES x I <sub>n</sub>								
THERMAL RELEASE I <sub>rh</sub>								
N. POLI x I <sub>n</sub>								
SIZE		10	50	16			4	4
SETTING		B	B	B			B	B
TYPE	FG7	FG7	FG7	FG7			FG7	FG7
NO. OF CORES X AREA	3x 50+1x 25	5G6	3x 35+1x 25	5G10			3G2,5	3G2,5
GROUND WIRE (GW)	1x 25		1x 25					
NO. OF WIRE X POLE	1	1	1	1			1	1
LENGTH		40	30	40			30	20
ΔV%		0,31	0,65	0,42			1,48	0,29
CURRENT CARRYING CAPACITY		48	144	66			31	31
MINIMUM Icc		636	3,057	1,080			355	530
MAX Icc		1,237	4,261	2,005			355	530
MAXIMUM LENGTH CHECKED		129	102	140			107	107

REFERENCE NUMBER OF DEVICE	1	2	3	4	5	6	7	8	9	10	11	12
PROJECT NAME	SO9_04											

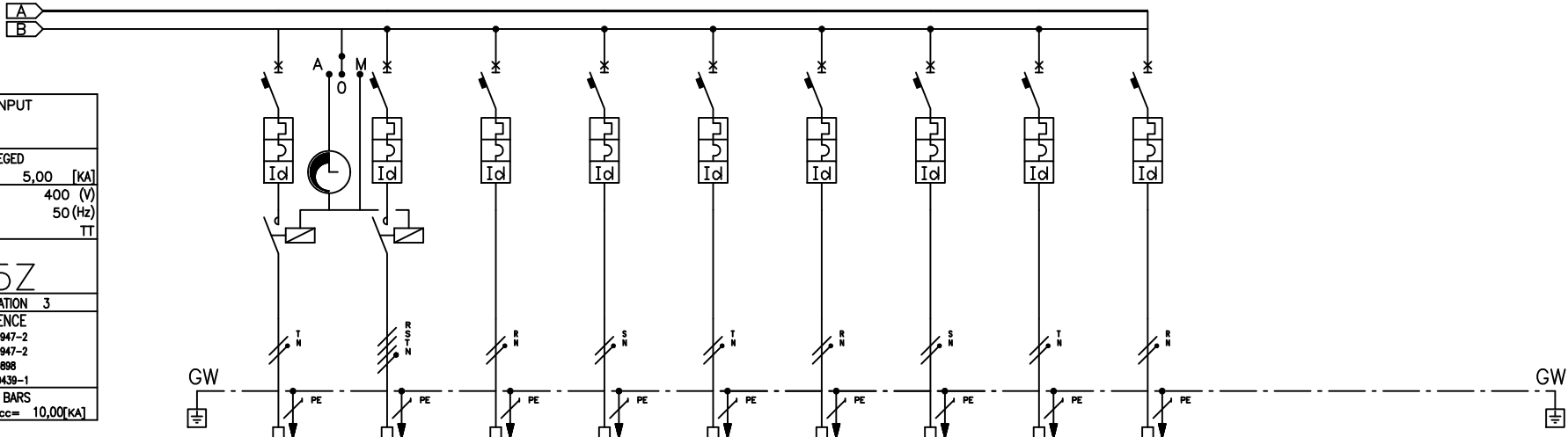

PLANT INPUT	
FAULT CURRENT ALLEGED ON PANELBOARD	5,00 [kA]
RATED VOLTAGE	400 (V)
RATED FREQUENCY	50 (Hz)
SYSTEM OF NEUTRAL	TT
PANELBOARD NAME	
PB5Z	
DP 31	SEGREGATION 3
NORMATIVE REFERENCE	
SWITCH	CEI EN 60947-2
MODULAR SWITCH	CEI EN 60947-2
	CEI EN 60898
PANELBOARD	CEI EN 60439-1
DIMENSION COPPER BARS	
In=	160 [A]
Icc=	10,00[kA]

USER	SWITCH NAME	
	CIRCUIT NAME	
	DESCRIPTION OF THE CIRCUIT	
	INSTALLED ELECTRIC POWER	[kVA]
	INSTALLED ELECTRIC POWER	[kW]
	COEF. OF CONTEMPORANEITY	
	COEF. OF UTILISATION	
	USED ELECTRIC POWER	[kW]
	THREE OR MONO PHASE SYSTEM	
	VOLTAGE	[V]
Cos φ		
ELECTRICAL CURRENT USED	[A]	
DATA PANELBOARD	Icc ALLEGED	[kA]
	TYPE	
SWITCH OR DISCONNECTOR	SIZE	
	CHARACTERISTICS	
	MAGNETIC RELEASE I <sub>rm</sub>	[A]
	THERMAL RELEASE I <sub>rh</sub>	[A]
	BREAKING CAPACITY	[kA]
RESIDUAL CURRENT DEVICE	I <sub>Δn</sub>	[A]
	RATED SENSITIVITY	[A]
COMMAND DEVICE	DELAY	[ms]
	TYPE	
THERMAL RELAY	N. POLES x I <sub>n</sub>	[A]
	THERMAL RELEASE I <sub>rh</sub>	[A]
FUSE	N. POLI x I <sub>n</sub>	[A]
	SIZE	[mm <sup>2</sup> ]
WIRE	CONNECTION	
	SETTING	
	TYPE	
	NO. OF CORES X AREA	[mm <sup>2</sup> ]
	GROUND WIRE (GW)	[mm <sup>2</sup> ]
CHECK	NO. OF WIRE X POLE	
	LENGTH	[m]
	ΔV%	[%]
	CURRENT CARRYING CAPACITY	[A]
	WIRE	[A <sup>2</sup> t]
WIRE	MINIMUM Icc	[A]
	MAX Icc	[A]
	MAXIMUM LENGTH CHECKED	[m]

	Q9	Q10	Q11	Q12	Q13	Q14	Q15	Q16	Q17											
	L3	L4	FM1	FM2	FM3															
	Palms lighting	External light lamp pole	Room 5.Z01 - 5.Z02 5.Z03	Baths	Cylindrical bollard	Rack Data	Panel for fire alarm	Spare	Spare											
	0,61	3,33	1,11	0,56	0,39	0,89	0,22													
	0,55	3,00	1,00	0,50	0,35	0,80	0,20													
	1,00	1,00	1,00	1,00	1,00	1,00	1,00													
	1,00	1,00	1,00	1,00	1,00	1,00	1,00													
	0,55	3,00	1,00	0,50	0,35	0,80	0,20													
	M	T	M	M	M	M	M													
	220	380	220	220	220	220	220													
	0,90	0,90	0,90	0,90	0,90	0,90	0,90													
	2,8	5,1	5,1	2,5	1,8	4,0	1,0													
	5,000	5,000	5,000	5,000	5,000	5,000	5,000													
	Miniature	Miniature	Miniature	Miniature	Miniature	Miniature	Modulare													
	2x16	4x16	2x16	2x16	2x16	2x16	2x10													
	C	C	C	C	C	C	C													
	160	160	160	160	160	160	100													
	16,0	16,0	16,0	16,0	16,0	16,0	10,0													
	10,0	10,0	10,0	10,0	10,0	10,0	10,0													
	1,200E+03	1,200E+03	1,200E+03	1,200E+03	1,200E+03	1,200E+03	1,200E+03													
	0,03	0,03	0,03	0,03	0,03	0,03	0,03													
	Contactor	Contactor																		
	2x25	4x25																		
	16	25	6	6	16	6	4													
	B	B	B	B	B	B	B													
	FG7	FG7	FG7	FG7	FG7	FG7	FG7													
	3G10	5G16	3G4	3G4	3G10	3G4	3G2,5													
	1	1	1	1	1	1	1													
	210	180	30	20	140	10	10													
	1,21	0,61	0,81	0,26	0,52	0,21	0,08													
	74	89	42	42	74	42	31													
	2,496E+06	6,391E+06	3,994E+05	3,994E+05	2,496E+06	3,994E+05	1,560E+05													
	213	386	568	844	319	1.614	1.041													
	213	762	568	844	319	1.614	1.041													
	279	434	107	107	279	107	107													

PROJECT NAME S09\_04

PLANT INPUT	
FAULT CURRENT ALLEGED ON PANELBOARD	1,00 [KA]
RATED VOLTAGE	400 (V)
RATED FREQUENCY	50 (Hz)
SYSTEM OF NEUTRAL	TT
PANELBOARD NAME	
PB5A	
DP 31	SEGREGATION 3
NORMATIVE REFERENCE	
SWITCH	CEI EN 60947-2
MODULAR SWITCH	CEI EN 60947-2
	CEI EN 60898
PANELBOARD	CEI EN 60439-1
DIMENSION COPPER BARS	
In=	16 [A] Icc= 6,00 [KA]

PANEL NAME  
Panelboard Building 5 – floor A



















































CLIENT :

OBJECT :

*Cathedral of Benghazi – Building 5*

TABLE: 09

# LEGEND SYMBOLS

SYMBOL	DESCRIPTION	SYMBOL	DESCRIPTION	SYMBOL	DESCRIPTION	SYMBOL	DESCRIPTION
	BATTERY ACCUMULATORI		PUSH SWITCH NO N.A.		CONTACTOR		METER
	RECTIFIER RADDRIZZATORE		PUSH SWITCH NC N.C.		PHASE WIRE		AMPEROMETRIC AND AMMETRIC SWITCH
	INVERTER C.C. - A.C.		SIGNAL LAMP		NEUTRAL WIRE		RELAY
	CONTROL ISOLATION "ISOLTESTER"		ELECTRIC SIREN		EXTRACTABLE SWITCH		DELAY TO DISEXCITATION RELAY
	AUXILIARY CONTACT NO		FUSE		SAFETY ISOLATING TRASFORMERS		DELAY TO EXCITATION RELAY
	AUXILIARY CONTACT NC		DIODE		TRANSFORMER		TWILIGHT SWITCH
	AUXILIARY CONTACT OF THERMAL RELAY NO		AUTOMATIC CIRCUIT BREAKER		RIDUTTORE DI CORRENTE (TA)		THREE PHASE MOTOR A.C.
	AUXILIARY CONTACT OF THERMAL RELAY NC		ISOLATOR		EARTH CONNECTION		MONO PHASE MOTOR A.C.
	AUXILIARY CONTACT TIMED TO THE EXCITATION NO		MAGNETIC AND THERMAL SWITCH		KEY LOCK		THREE PHASE CAPACITOR
	AUXILIARY CONTACT TIMED TO THE EXCITATION NC		MAGNETIC, THERMAL AND RESIDUAL CURRENT SWITCH		LOCK		
	AUXILIARY CONTACT TIMED TO THE DISEXCITATION NO		RESIDUAL CURRENT SWITCH		TIME SWITCH		
	AUXILIARY CONTACT TIMED TO THE DISEXCITATION NC		SWITCH		TERMINAL		
	PROXIMITY SWITCH NO		FUSE-DISCONNECTOR		VOLTMETER		
	PROXIMITY SWITCH NC		EARTHING SWITCH		AMPEROMETER		

PROJECT NAME S09\_04

PLANT INPUT	
FAULT CURRENT ALLEGED ON PANELBOARD	1,00 [KA]
RATED VOLTAGE	400 (V)
RATED FREQUENCY	50 (Hz)
SYSTEM OF NEUTRAL	TT
PANELBOARD NAME	
PB5A	
DP 31	SEGREGATION 3
NORMATIVE REFERENCE	
SWITCH	CEI EN 60947-2
MODULAR SWITCH	CEI EN 60947-2
	CEI EN 60898
PANELBOARD	CEI EN 60439-1
DIMENSION COPPER BARS	
In=	16 [A] lcc= 6,00 [KA]

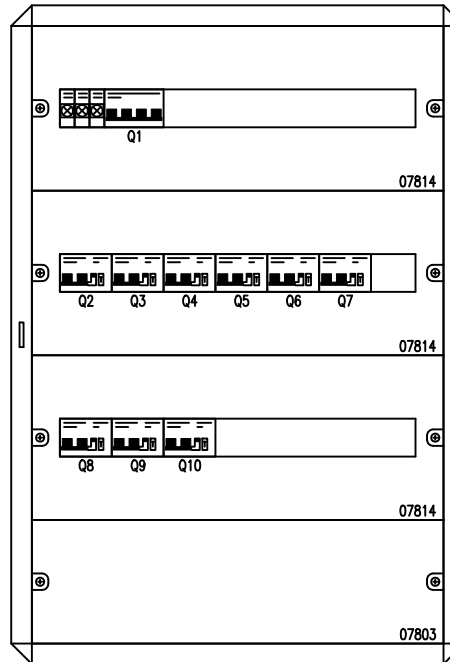

DIMENSION PANEL

HEIGHT [mm] : 800      BREADTH [mm] : 550      DEPTH[mm] : 300

REFERENCE NUMBER OF DEVICE	1	2	3	4	5	6	7	8	9	10	11	12
PROJECT NAME	S09_04											

PLANT INPUT	
FAULT CURRENT ALLEGED ON PANELBOARD	1,00 [kA]
RATED VOLTAGE	400 (V)
RATED FREQUENCY	50 (Hz)
SYSTEM OF NEUTRAL	TT
PANELBOARD NAME	
PB5A	
DP 31	SEGREGATION 3
NORMATIVE REFERENCE	
SWITCH	CEI EN 60947-2
MODULAR SWITCH	CEI EN 60947-2
	CEI EN 60898
PANELBOARD	CEI EN 60439-1
DIMENSION COPPER BARS	
In=	16 [A]
Icc=	6,00 [kA]

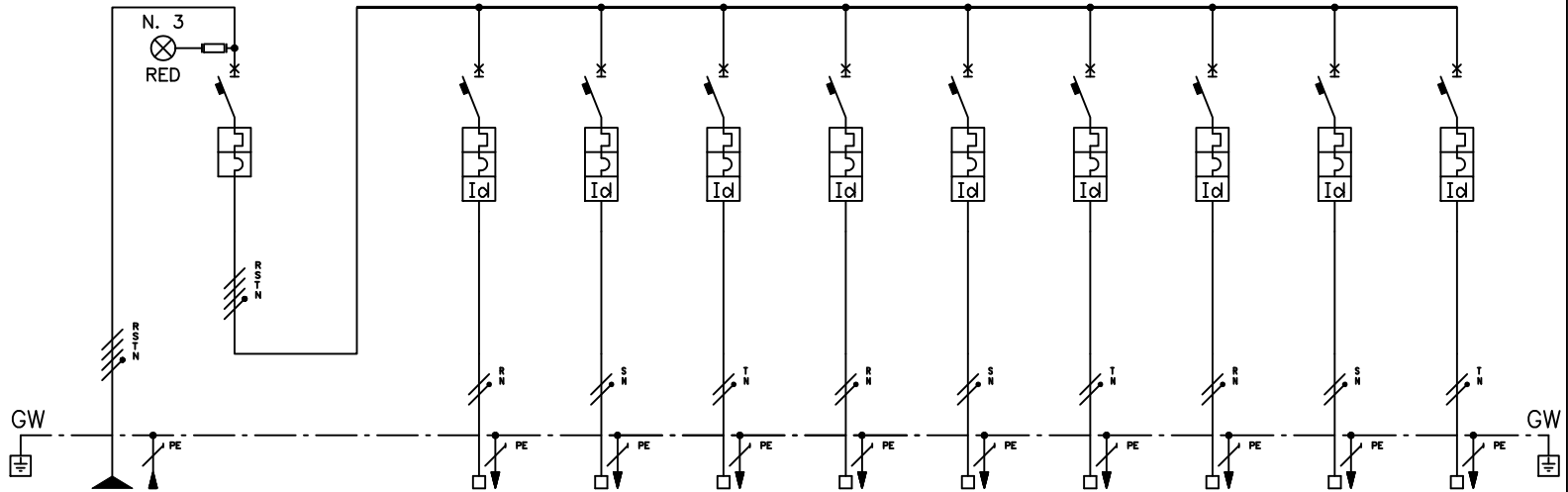

USER	SWITCH NAME	Q1	Q2	Q3	Q4	Q5	Q6	Q7	Q8	Q9	Q10
	CIRCUIT NAME		L1	L2	L3	L4			FM1	FM2	
	DESCRIPTION OF THE CIRCUIT	Main lighting and sockets sw itch	Room 5.A 01 Lights 1	Room 5.A 01 Lights 2	Room 5.A 01 Lights 3	Room 5.A 01 Lights 4	Spare	Spare	Room 5.A 01	Room 5.A 01	Video entryphone
	INSTALLED ELECTRIC POWER [kVA]	5,65	0,83	0,47	0,50	0,22			1,11	1,56	0,33
	INSTALLED ELECTRIC POWER [kW]	4,52	0,75	0,42	0,45	0,20			1,00	1,40	0,30
	COEF. OF CONTEMPORANEITY	1,00	1,00	1,00	1,00	1,00			1,00	1,00	1,00
	COEF. OF UTILISATION	1,00	1,00	1,00	1,00	1,00			1,00	1,00	1,00
	USED ELECTRIC POWER [kW]	4,52	0,75	0,42	0,45	0,20			1,00	1,40	0,30
	THREE OR MONO PHASE SYSTEM	T	M	M	M	M			M	M	M
	VOLTAGE [V]	380	220	220	220	220			220	220	220
	cos f	0,80	0,90	0,90	0,90	0,90			0,90	0,90	0,90
	ELECTRICAL CURRENT USED [A]	8,6	3,8	2,1	2,3	1,0			5,1	7,1	1,5
DATA PANELBOARD	Icc ALLEGED [kA]	1,000	1,000	1,000	1,000	1,000	1,000	1,000	1,000	1,000	1,000
	TYPE	Miniature	Miniature	Miniature	Miniature	Miniature	Miniature	Miniature	Miniature	Miniature	Miniature
	SIZE	4x16	2x10	2x10	2x10	2x10	2x10	2x10	2x16	2x16	2x16
	CHARATERISTICS	C	C	C	C	C	C	C	C	C	C
SWITCH OR DISCONNECTOR	MAGNETIC RELEASE I <sub>rm</sub> [A]	160	100	100	100	100	100	100	160	160	160
	THERMAL RELEASE I <sub>rh</sub> [A]	16,0	10,0	10,0	10,0	10,0	10,0	10,0	16,0	16,0	16,0
	BREAKING CAPACITY [kA]	6,0	6,0	6,0	6,0	6,0	6,0	6,0	6,0	6,0	6,0
	I <sub>∞t</sub> [A²t]	4,800E+03	4,800E+03	4,800E+03	4,800E+03	4,800E+03	4,800E+03	4,800E+03	4,800E+03	4,800E+03	4,800E+03
RESIDUAL CURRENT DEVICE	RATED SENSITIVITY [A]		0,03	0,03	0,03	0,03	0,03	0,03	0,03	0,03	0,03
	DELAY [ms]										
COMMAND DEVICE	TYPE										
	N. POLES x In [A]										
THERMAL RELAY	THERMAL RELEASE I <sub>rh</sub> [A]										
FUSE	N. POLI x In [A]										
CONNECTION	SIZE [mm²]		4	4	4	4			6	6	6
	SETTING		B	B	B	B			B	B	B
	TYPE	FG7	FG7	FG7	FG7	FG7			FG7	FG7	FG7
WIRE	NO. OF CORES X AREA [mm²]	5G4	3G2,5	3G2,5	3G2,5	3G2,5			3G4	3G4	3G4
	GROUND WIRE (GW) [mm²]										
	NO. OF WIRE X POLE	1	1	1	1	1			1	1	1
	LENGTH [m]		30	30	30	20			30	30	60
	Δ V% [%]		0,97	0,53	0,59	0,17			0,81	1,13	0,48
CHECK	CURRENT CARRYING CAPACITY [A]		31	31	31	31			42	42	42
	k² S² [A²t]		1,560E+05	1,560E+05	1,560E+05	1,560E+05			3,994E+05	3,994E+05	3,994E+05
WIRE	MINIMUM I <sub>cc</sub> [A]		334	334	334	468			492	492	274
	MAX I <sub>cc</sub> [A]		334	334	334	468			492	492	274
	MAXIMUM LENGTH CHECKED [m]		106	106	106	106			107	107	107